

PHFR SERIES

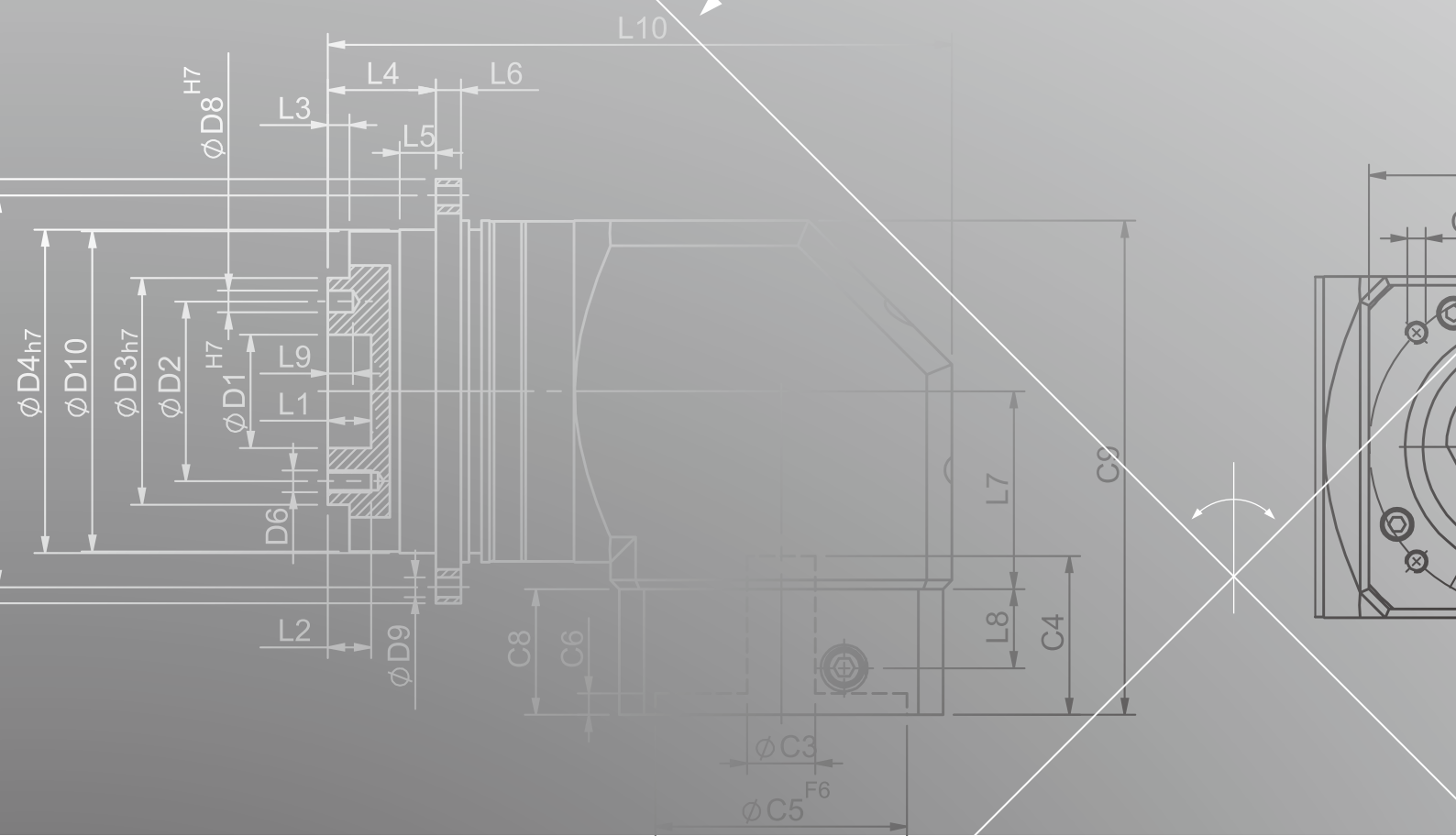

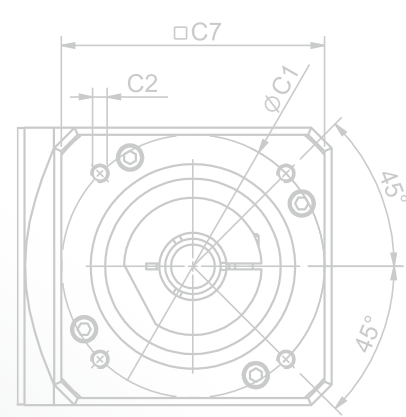

PHFR Single Stage Dimensions

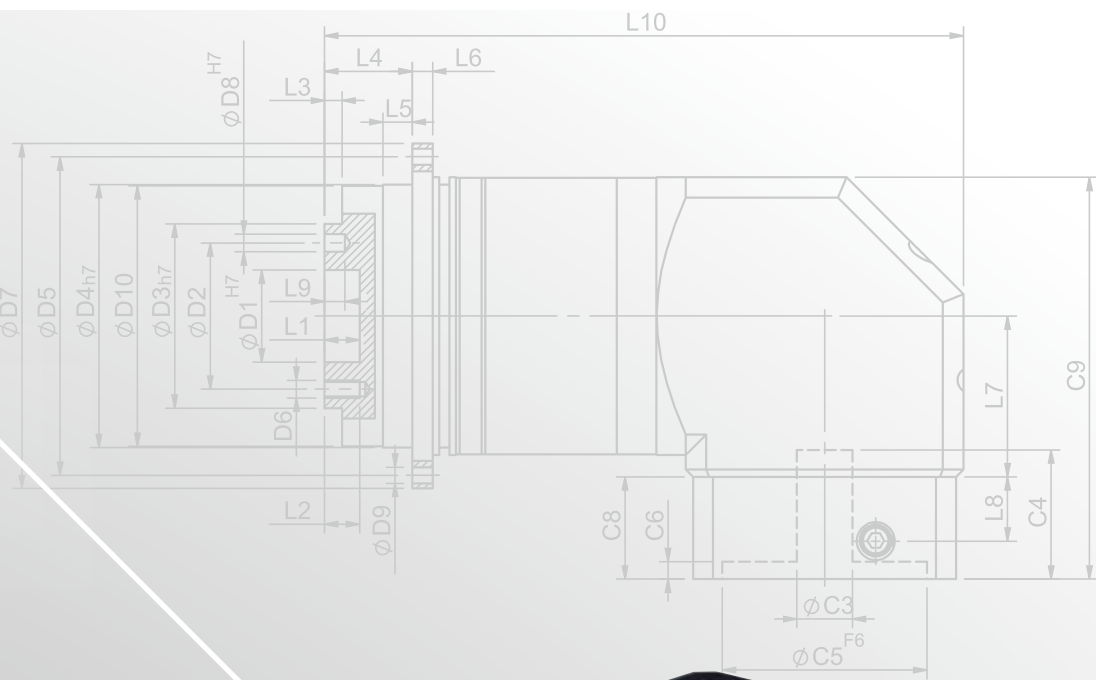
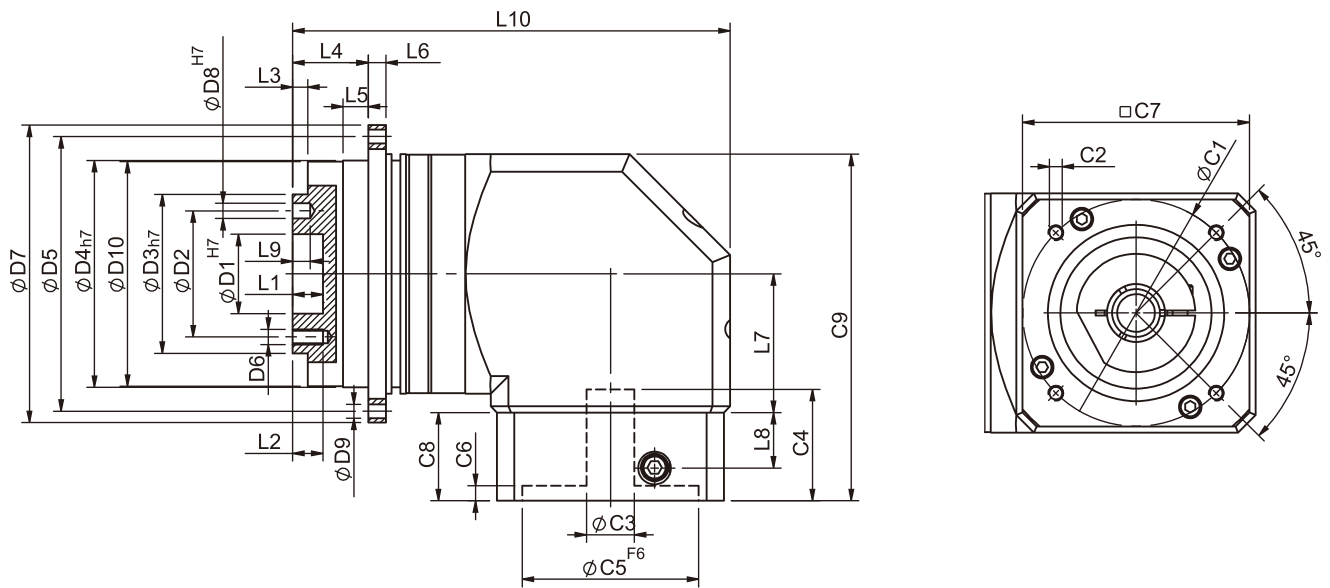

Specifications

Unit:mm

Dimensions	PHFR42	PHFR60	PHFR90	PHFR115	PHFR142	PHFR200	PHFR255
D1 _{H7}	12	20	31.5	40	50	80	100
D2	20	31.5	50	63	80	125	140
D3 _{h7}	28	40	63	80	100	160	180
D4 _{h7}	47	64	90	110	140	200	255
D5	67	79	109	135	168	233	280
D6	M3x0.5P	M5x0.8P	M6x1.0P	M6x1.0P	M8x1.25P	M10x1.5P	M16x2.0P
D7	72	86	118	145	179	247	300
D8 _{H7}	3	5	6	6	8	10	12
D9	3.4	4.5	5.5	5.5	6.6	9	13.5
D10	46.2	63.2	89.2	109.2	139.2	199.2	254.2
L1	4	8	12	12	12	16	20
L2	6	7.2	12	13.5	16	22.5	30.5
L3	3	3	6	6	6	8	12
L4	19.5	19.5	30	29	38	50	66
L5	7	7	10	10	14.6	15	20
L6	4	4	7	8	10	12	18
L7	32.2	44.8	55	69	71	92.5	92.5
L8	13.5	21.5	22	32	47.8	44	60
L9	4	6	7	7	7	10	10
L10	92.2	128.3	173.6	204.2	250.7	330.7	392.2
C1 ²	46	70	90	90	145	200	215
C2 ²	M4x0.7P	M5x0.8P	M6x1.0P	M6x1.0P	M8x1.25P	M12x1.75P	M12x1.75P
C3 ²	$\leq 8/\leq 11$	$\leq 14/\leq 19$	$\leq 19/\leq 24$	$\leq 24/\leq 32$	≤ 35	≤ 50	≤ 55
C4 ²	29	34	44	53.5	76.8	78.8	98.7
C5 ² _{F6}	30	50	70	70	110	114.3	180
C6 ²	6	5	5	5.5	9	6	6
C7 ²	42.6	60	90	115	140	180	220
C8 ²	25	33	35	48	65	65	85
C9 ²	78.5	112.8	137.5	176.5	225.5	246.5	266.5

★ C1~C9 are motor specific dimensions(metric std shown), Size may vary according to motor flange.

★ Specification subject to change without notice.

PHFR Double Stage Dimensions-1

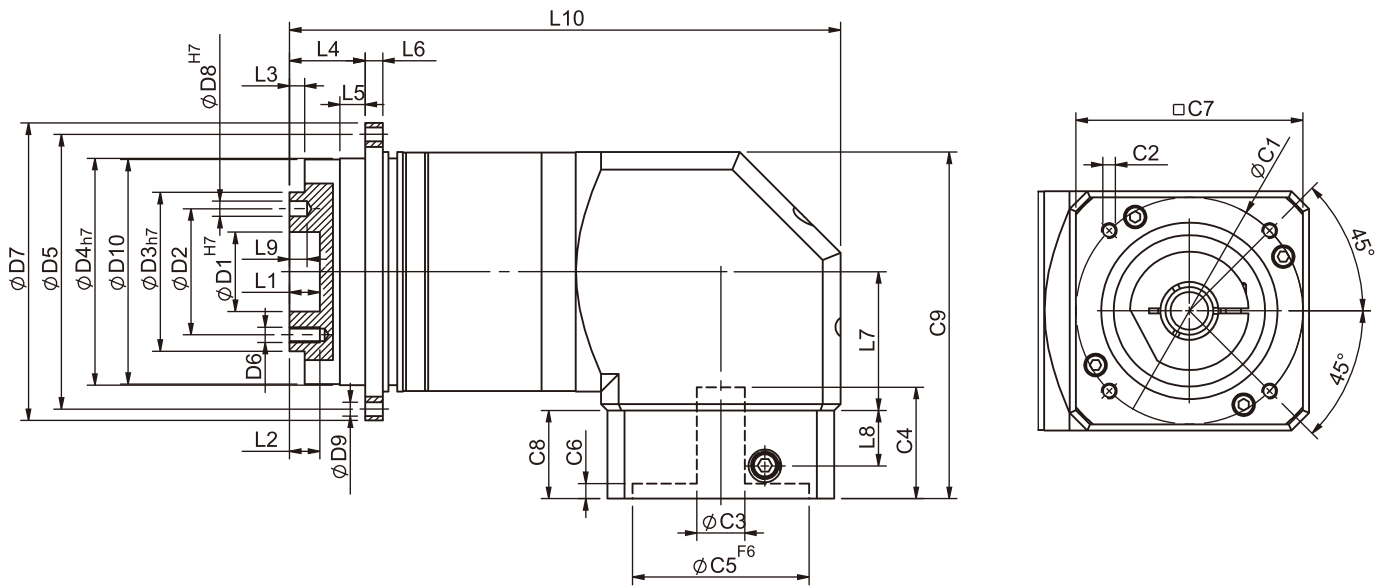

Specifications

Unit:mm

Dimensions	PHFR42	PHFR60	PHFR90
D1 _{H7}	12	20	31.5
D2	20	31.5	50
D3 _{h7}	28	40	63
D4 _{h7}	47	64	90
D5	67	79	109
D6	M3x0.5P	M5x0.8P	M6x1.0P
D7	72	86	118
D8 _{H7}	3	5	6
D9	3.4	4.5	5.5
D10	46.2	63.2	89.2
L1	4	8	12
L2	6	7.2	12
L3	3	3	6
L4	19.5	19.5	30
L5	7	7	10
L6	4	4	7
L7	32.2	44.8	55
L8	13.5	21.5	22
L9	4	6	7
L10	119.9	163.3	218.6
C1 ²	46	70	90
C2 ²	M4x0.7P	M5x0.8P	M6x1.0P
C3 ²	≤ 8	≤ 14	≤ 19/≤ 24
C4 ²	29	34	44
C5 ² F6	30	50	70
C6 ²	6	5	5
C7 ²	42.6	60	90
C8 ²	25	33	35
C9 ²	78.5	112.8	137.5

* C1~C9 are motor specific dimensions(metric std shown), Size may vary according to motor flange.

* Specification subject to change without notice.

PHFR Double Stage Dimensions-2

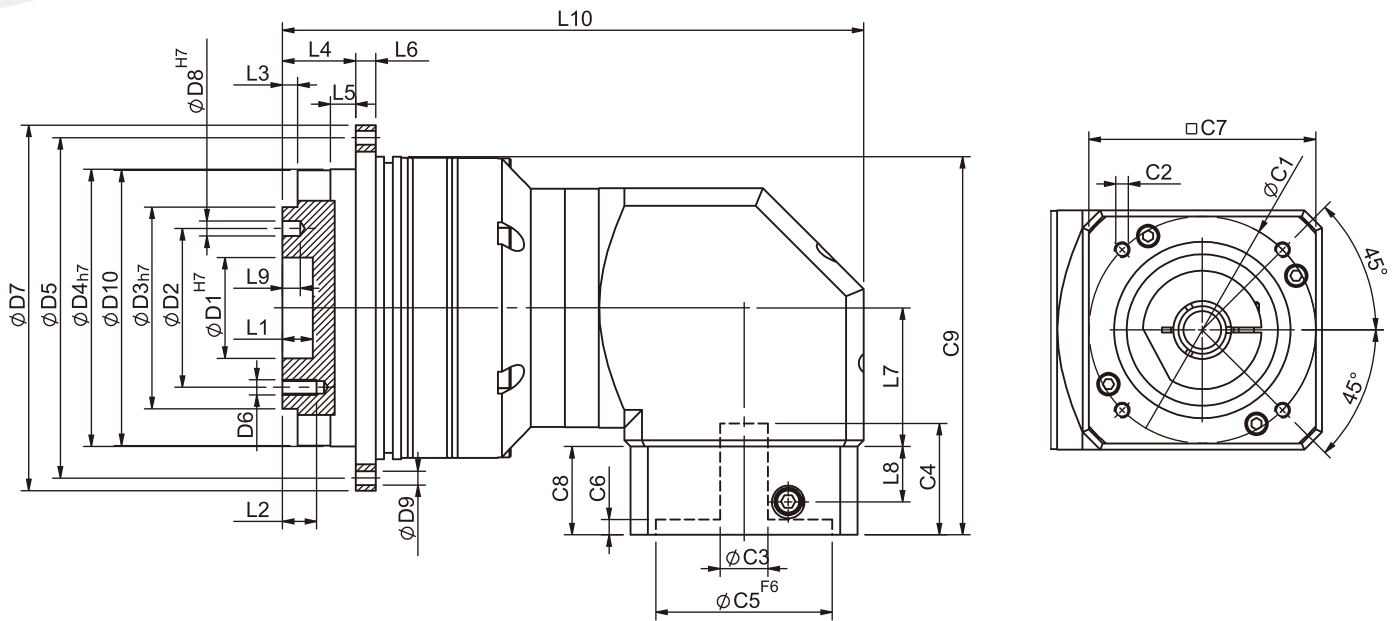

Specifications

Unit:mm

Dimensions	PHFR60T	PHFR90T	PHFR115T	PHFR142T	PHFR200T	PHFR255T
D1 _{H7}	20	31.5	40	50	80	100
D2	31.5	50	63	80	125	140
D3 _{h7}	40	63	80	100	160	180
D4 _{h7}	64	90	110	140	200	255
D5	79	109	135	168	233	280
D6	M5x0.8P	M6x1.0P	M6x1.0P	M8x1.25P	M10x1.5P	M16x2.0P
D7	86	118	145	179	247	300
D8 _{H7}	5	6	6	8	10	12
D9	4.5	5.5	5.5	6.6	9	13.5
D10	63.2	89.2	109.2	139.2	199.2	254.2
L1	8	12	12	12	12	20
L2	7.2	12	13.5	16	22.5	30.5
L3	3	6	6	6	8	12
L4	19.5	30	29	38	50	66
L5	7	10	10	14.6	15	20
L6	4	7	8	10	12	18
L7	32.2	44.8	55	69	71	92.5
L8	13.5	21.5	22	32	47.8	44
L9	4	7	7	7	10	10
L10	130.6	173.8	230.6	270.7	361.4	439.2
C1 ²	46	70	90	90	145	200
C2 ²	M4x0.7P	M5x0.8P	M6x1.0P	M6x1.0P	M8x1.25P	M12x1.75P
C3 ²	≤ 8/≤ 11	≤ 14/≤ 19	≤ 19/≤ 24	≤ 24/≤ 32	≤ 35	≤ 50
C4 ²	29	34	44	53.5	76.8	78.8
C5 ² _{F6}	30	50	70	70	110	114.3
C6 ²	6	5	5	5.5	9	6
C7 ²	42.6	60	90	115	140	92.5
C8 ²	25	33	35	48	65	65
C9 ²	84.4	125.3	150	176.5	225.5	284

* C1~C9 are motor specific dimensions(metric std shown), Size may vary according to motor flange.

* Specification subject to change without notice.

PHFR Flange Dimensions

PHFR42

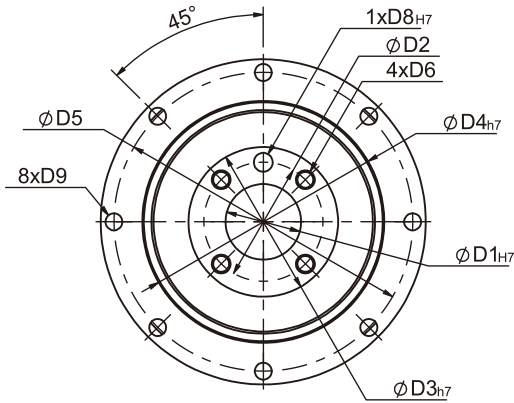

PHFR60 PHFR90

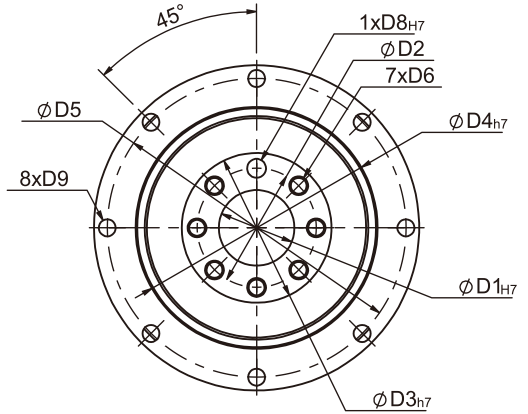

PHFR115

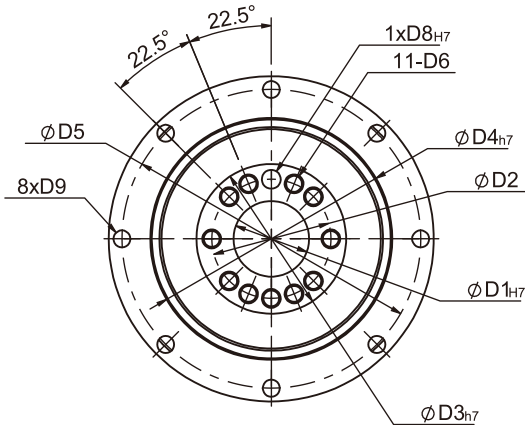

PHFR142 PHFR200

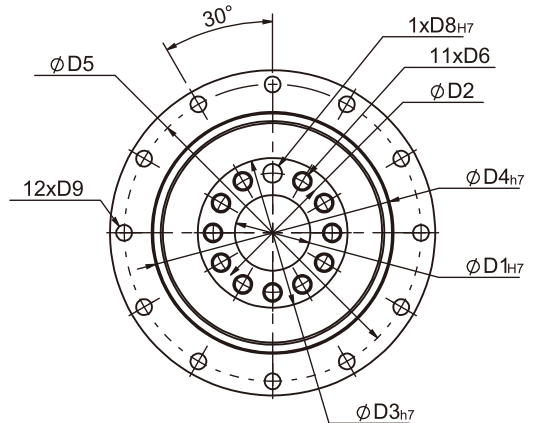

Specifications

Unit:mm

Dimensions	PHFR42	PHFR60	PHFR90	PHFR115	PHFR142	PHFR200
D1 H7	12	20	31.5	40	50	80
D2	20	31.5	50	63	80	125
D3 h7	28	40	63	80	100	160
D4 h7	47	64	90	110	140	200
D5	67	79	109	135	168	233
D6	M3x0.5P	M5x0.8P	M6x1.0P	M6x1.0P	M8x1.25P	M10x1.5P
D8 H7	3	5	6	6	8	10
D9	3.4	4.5	5.5	5.5	6.6	9

★ Specification subject to change without notice.

PHFR Specifications Table

Specifications		Stage	Ratio	PHFR-42	PHFR-60	PHFR-90	PHFR-115	PHFR-142	PHFR-200	PHFR-255
Nominal Output Torque T_{2N}	N • m	1	3	-	40	105	180	340	580	950
			4	16	43	110	240	500	1100	1500
			5	17	50	130	290	600	1200	1800
			7	14	44	125	270	530	1100	1750
			10	17	50	130	260	540	900	1500
			14	14	44	125	270	530	1100	1750
		20	11	37	95	220	430	900	1450	
		Stage	Ratio	PHFR-42	PHFR-60 PHFR-60T	PHFR-90 PHFR-90T	PHFR-115T	PHFR-142T	PHFR-200T	PHFR-255T
		2	15	-	40	105	180	600	1200	2000
			20	16	43	110	240	600	1200	2000
			25	17	50	130	290	600	1200	2000
			30	17	40	105	180	600	1200	2000
			35	17	50	130	290	600	1200	2000
			40	16	43	110	240	600	1200	2000
			50	17	50	130	290	600	1200	2000
			70	14	44	125	270	530	1100	1750
		100	11	37	95	220	430	900	1450	
		140	14	44	125	270	530	1100	1750	
200	11	37	95	220	430	900	1450			
Emergency Stop Torque T_{2NOT}	N • m		3.0 times of Nominal Output Torque (*Max. Output Torque T_{2B} = 60% of Emergency Stop Torque)							
Nominal Input Speed n_{1N}	rpm	1,2	3-200	5000	5000	4000	4000	3000	3000	2000
Max. Input Speed n_{1max}	rpm	1,2	3-200	10000	10000	8000	8000	6000	6000	4000
Micro Backlash P_0	arcmin	1	3-20	-	-	≤ 3	≤ 2	≤ 2	≤ 2	≤ 2
		2	15-200	-	-	≤ 5	≤ 4	≤ 4	≤ 4	≤ 4
Precision Backlash P_1	arcmin	1	3-20	≤ 5	≤ 5	≤ 5	≤ 4	≤ 4	≤ 4	≤ 4
		2	15-200	≤ 7	≤ 7	≤ 7	≤ 7	≤ 7	≤ 7	≤ 7
Standard Backlash P_2	arcmin	1	3-20	≤ 7	≤ 7	≤ 7	≤ 6	≤ 6	≤ 6	≤ 6
		2	15-200	≤ 9	≤ 9	≤ 9	≤ 9	≤ 9	≤ 9	≤ 9
Torsional Rigidity	N • m / arcmin	1,2	3-200	6	12	30	80	150	450	1000
Max. Bending Moment M_{2kB}^1	N • m	1,2	3-200	43	125	288	503	1470	2950	6500
Max. Axial Load F_{2aB}^1	N	1,2	3-200	1015	1340	2868	3890	9850	12560	21850
Operating Temp.	°C		3-200	-10 °C ~ +90 °C						
Service Life	hr		3-200	20,000 (10,000/ Continuous operation)						
Efficiency	%	1	3-20	≥ 95%						
		2	15-200	≥ 92%						
Weight	kg	1	3-20	1.0	2.3	6.6	13.5	25.1	50	85
		2	15-200	1.1	3.2/2.2	8.6/5.3	14.8	26.7	55	88
Mounting Position	-	1,2	3-200	Any direction						
Noise Level ²	dBA/1m	1,2	3-200	62	64	66	68	70	72	74
Protection Class	-	1,2	3-200	IP65						
Lubrication	-	1,2	3-200	Synthetic Lubricant						
Inertia(J1)										
Stage	Ratio	unit		PHFR-42	PHFR-60	PHFR-90	PHFR-115	PHFR-142	PHFR-200	PHFR-255
1	3/4/5/7/9	Kg • cm ²		0.06	0.40	2.28	6.87	24.2	69.8	138.2
	10/14/20			0.05	0.30	1.45	4.76	14.5	50.3	103.6
Stage	Ratio			PHFR-42	PHFR-60(T)	PHFR-90(T)	PHFR-115T	PHFR-142T	PHFR-200T	PHFR-255T
2	15/20/25/35			0.06	0.40(0.08)	2.28(0.72)	3.02	7.83	27.7	80.3
	others			0.05	0.30(0.06)	1.45(0.38)	1.64	5.00	15.9	55.3
<p>* 1. Applied to the output shaft center @100rpm. * 2. Measured at 3000 rpm with no load. These values are measured by gearbox with ratio = 10 (1-stage) or ratio = 100 (2-stage) at nominal input speed or 3000 rpm (if nominal input speed is higher than 3000 rpm) with no load. ※ The above figures/specifications are subject to change without prior notice.</p>										

Products due to human error, natural disasters or other factors lead to poor or damaged, will not be covered under warranty.

PHF SERIES

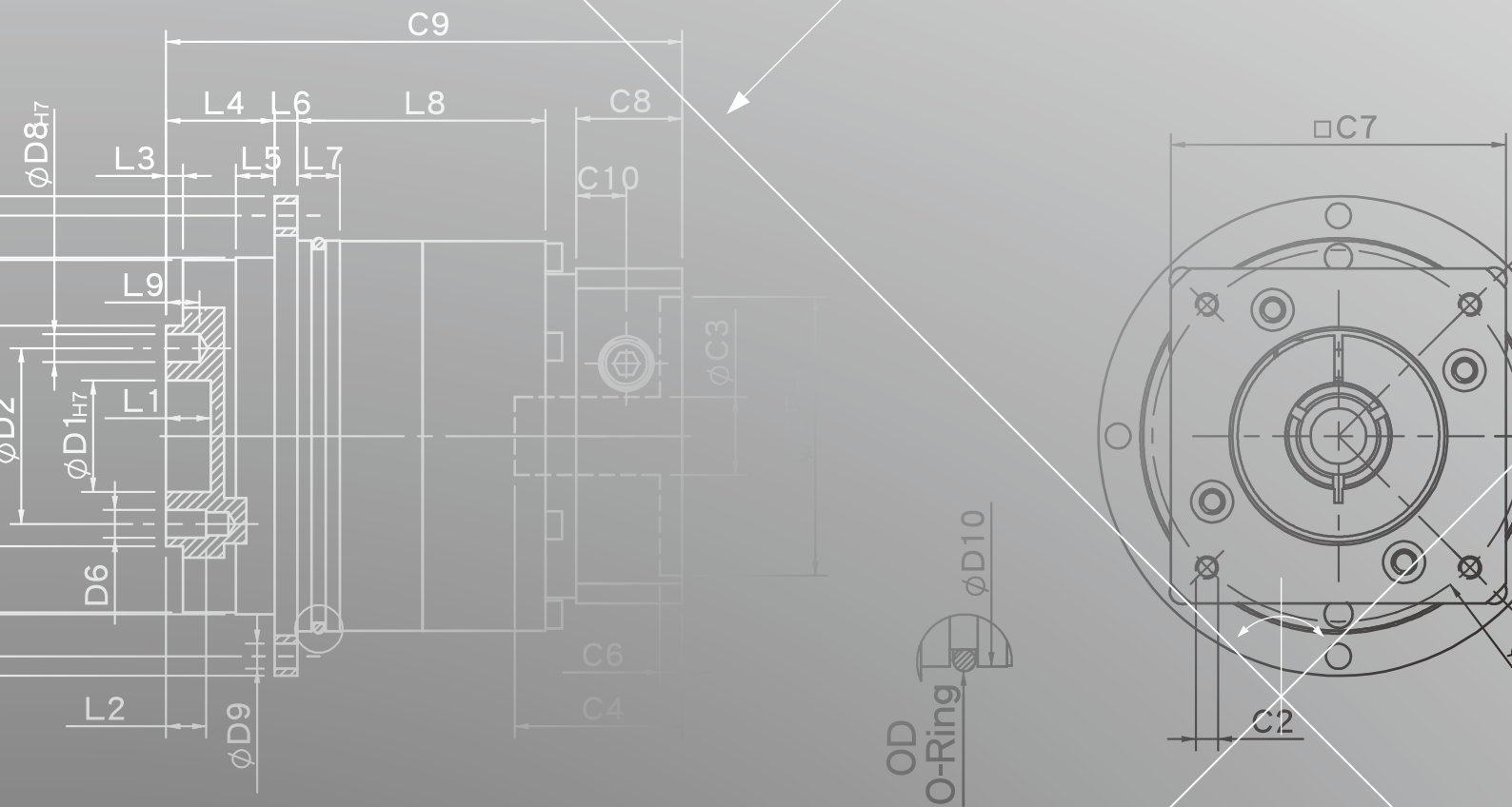

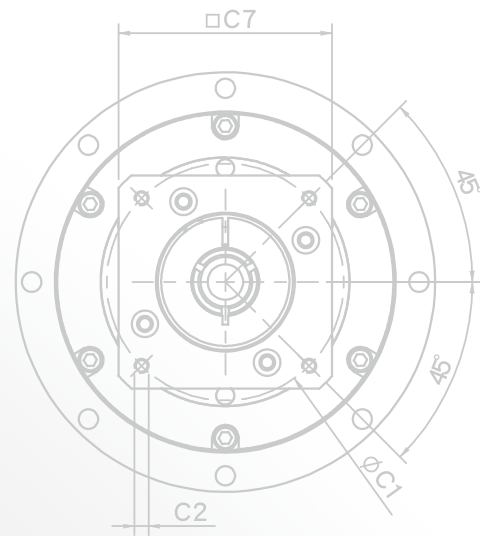
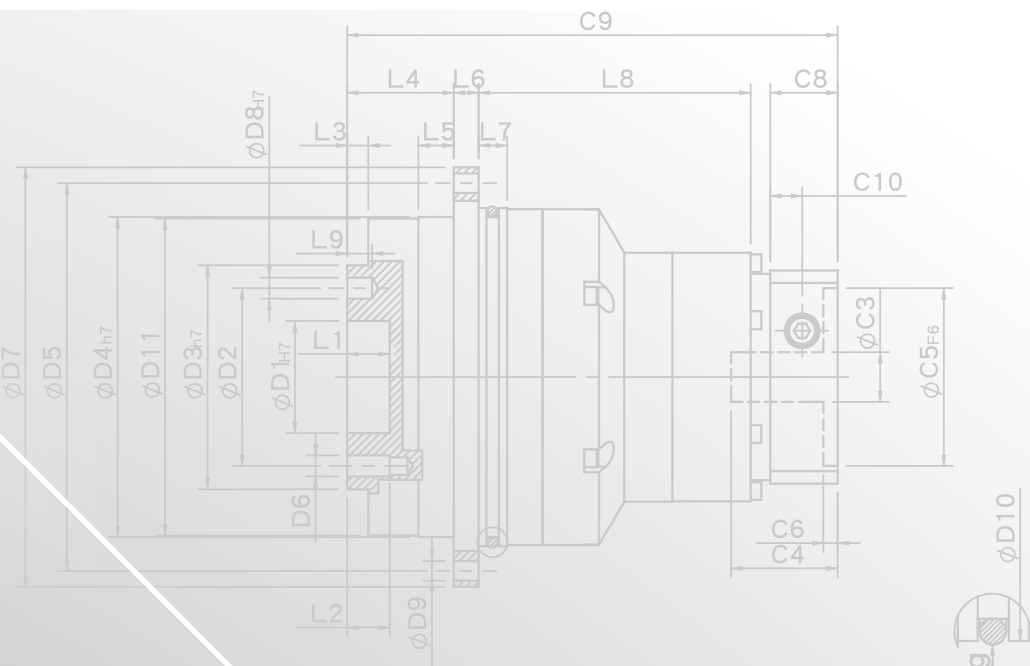

PHF SERIES FEATURES



Alloy steel gear with unique heat treatment. Additionally, with gear grinding process-ing to get the best accuracy, high wear resistance and high impact toughness.

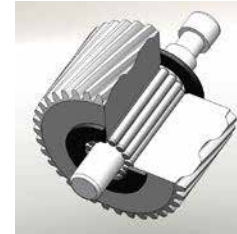

Planet gear transmission interface equipped with needle bearings, full needle roller bearings aligned without retainer achieve maximum exposure but smallest gap tolerances. Enhance over-all gear structure rigid and output torque.

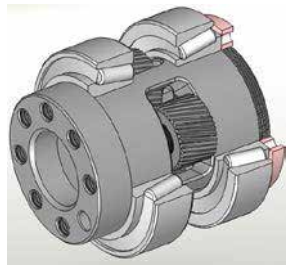

Planetary arm bracket and output shaft are one-piece constructed, using tapered roller bearings can bear the axial load and radial load that are more than deep groove ball bearings. Setting the bearing apart for larger span to reach the largest torsional rigidity and contribute high axial load and radial load capacity.

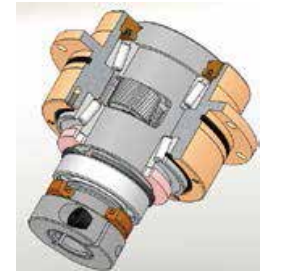

Input-end and motor shaft are coupled through a dynamic balanced collar clamping mechanism to ensure connection interface concentricity and zero slip power transmission at high speed.

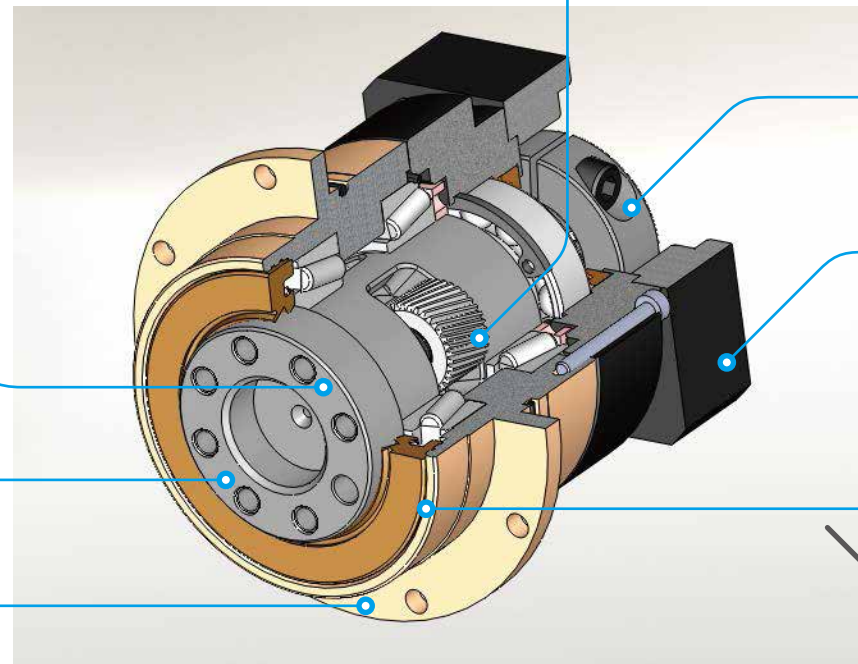

Advanced motor bracket design coupled with the input shaft bushing is easy to mount to any servo or stepper motor.

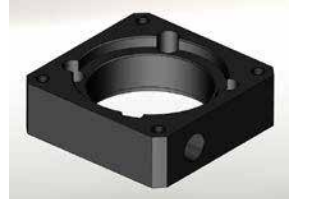

Grinding process to smooth surface of output shaft, and with oil seal to minimum friction coefficient and reducing start up load; result in the best seal-ability and extended lifespan. Hollow out-put shaft connect perfectly with circular flange drastically reducing the installation space.

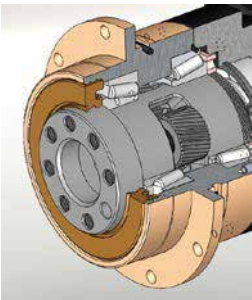

PHF series overall design suitable for combination operation with servo motor high-speed input and achieves maximum torque output. Hollow out-put shaft connects perfectly with circular flange drastically reducing the installation space. Precision helical gear design and gear processing create a planetary gearhead with low backlash operation, high efficiency, low noise and long lifespan.

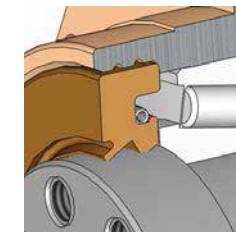

High-tech oil seal design on the upper lip guard against dust intruder, lower lip to guard against oil leak. Protection grade IP65 safeguards fully avoid leaking problem, and given it maintenance-free.

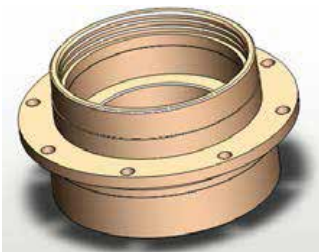

Advanced electroless nickel plating surface treatment resists scratch and corrosion. Suitable for stringent require of high-tech equipment. The gear box and internal gear ring are one-piece constructed, and then processed with advanced Germany gear shaper machinery for high-precision, high torque and abrade consumption.

Products due to human error, natural disasters or other factors lead to poor or damaged, will not be covered under warranty.

PHL
PHR
PHF
PGH
PUR
PUL
PGLH
PCL
PGC
PGE
PGRH
PGR
PGFR
PGF
PBC
PBE
PAE
PAC
PAN
PGS
PNS

PHF Single Stage Dimensions

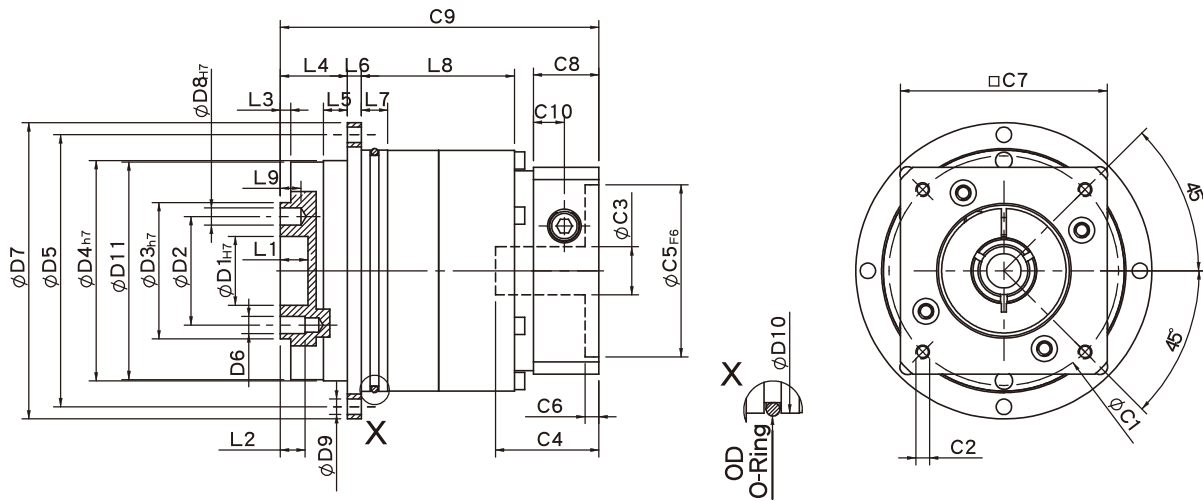

Specifications

Unit:mm

Dimensions	PHF42	PHF60	PHF90	PHF115	PHF142	PHF200	PHF255
D1 _{H7}	12	20	31.5	40	50	80	100
D2	20	31.5	50	63	80	125	140
D3 _{H7}	28	40	63	80	100	160	180
D4 _{H7}	47	64	90	110	140	200	255
D5	67	79	109	135	168	233	280
D6	M3x0.5P	M5x0.8P	M6x1.0P	M6x1.0P	M8x1.25P	M10x1.5P	M16x2.0P
D7	72	86	118	145	179	247	300
D8 _{H7}	3	5	6	6	8	10	12
D9	3.4	4.5	5.5	5.5	6.6	9	13.5
D10	60	70	95	120	152	212	255
D11	46.2	63.2	89.2	109.2	139.2	199.2	254.2
L1	4	8	12	12	12	12	20
L2	6	7.2	12	13.5	16	22.5	30.5
L3	3	3	6	6	6	8	12
L4	19.5	19.5	30	29	38	50	66
L5	7	7	10	10	14.6	15	20
L6	4	4	7	8	10	12	18
L7	5	7.7	8	10	12	17	39.5
L8	25	37.5	36.5	54.5	65	92	118
L9	4	6	7	7	7	10	10
C1 ²	46	70	90	115	145	200	235
C2 ²	M4x0.7P	M5x0.8P	M6x1.0P	M8x1.25P	M8x1.25P	M12x1.75P	M12x1.75P
C3 ²	≤8/≤11	≤14/≤19	≤19/≤24	≤24/≤32/≤38	≤35/≤38	≤50	≤55
C4 ²	28.1	36.5	41.2	51.1	69.7	81	112
C5 ² _{F6}	30	50	70	95	110	114.3	200
C6 ²	4	4	6.7	6	8.5	6	6
C7 ²	42	60	90	115	140	182	220
C8 ²	16.5	19	25.5	30	38	40	50
C9 ²	74.8	92.5	107	131.5	171.5	215	271
C10 ²	7.4	9	11.3	13.9	17.8	21	21
OD	56x2	66x2	90x3	110x3	145x3	200x5	238x5

* C1~C9 are motor specific dimensions(metric std shown), Size may vary according to motor flange.

* Specification subject to change without notice.

PHF Double Stage Dimensions-1

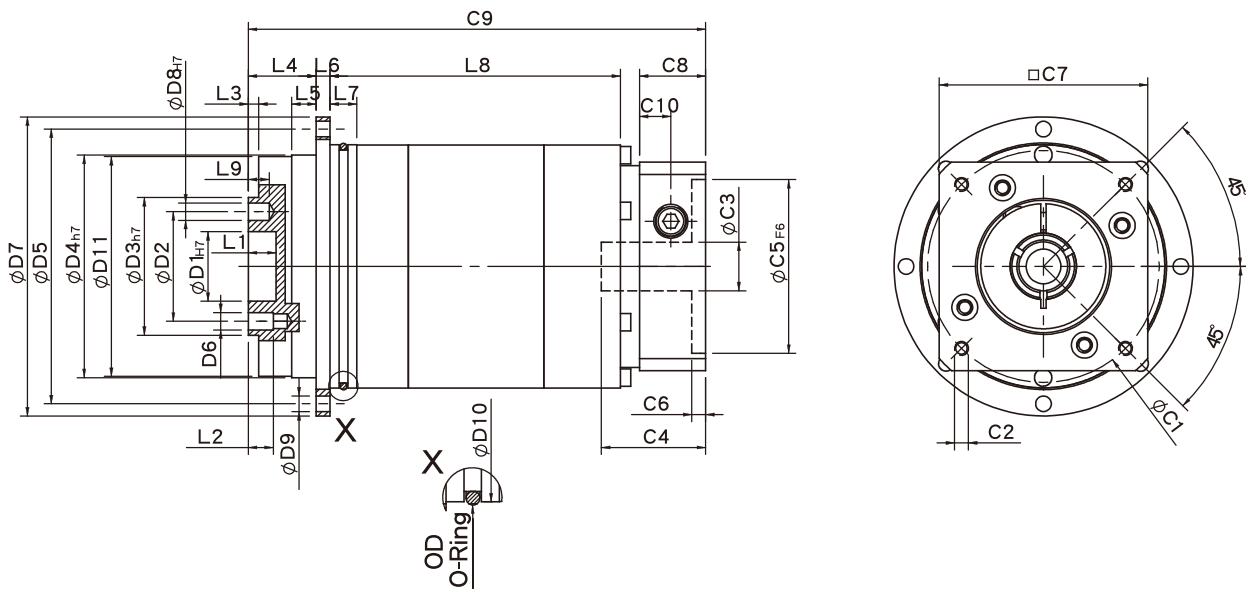

Specifications

Unit:mm

Dimensions	PHF42	PHF60	PHF90
D1 _{H7}	12	20	31.5
D2	20	31.5	50
D3 _{h7}	28	40	63
D4 _{h7}	47	64	90
D5	67	79	109
D6	M3x0.5P	M5x0.8P	M6x1.0P
D7	72	86	118
D8 _{H7}	3	5	6
D9	3.4	4.5	5.5
D10	60	70	95
D11	46.2	63.2	89.2
L1	4	8	12
L2	6	7.2	12
L3	3	3	6
L4	19.5	19.5	30
L5	7	7	10
L6	4	4	7
L7	5	7.7	8
L8	54.5	72.5	81.5
L9	4	6	7
C1 ²	46	70	90
C2 ²	M4x0.7P	M5x0.8P	M6x1.0P
C3 ²	≤8/≤11	≤14/≤19	≤19/≤24
C4 ²	28.1	36.4	41.2
C5 ² _{F6}	30	50	70
C6 ²	4	4	6.7
C7 ²	42	60	90
C8 ²	16.5	19	25.5
C9 ²	102.5	127.5	151.1
C10 ²	7.4	9	11.3
OD	56x2	66x2	90x3

* C1~C9 are motor specific dimensions(metric std shown), Size may vary according to motor flange.

* Specification subject to change without notice.

PHF Double Stage Dimensions-2

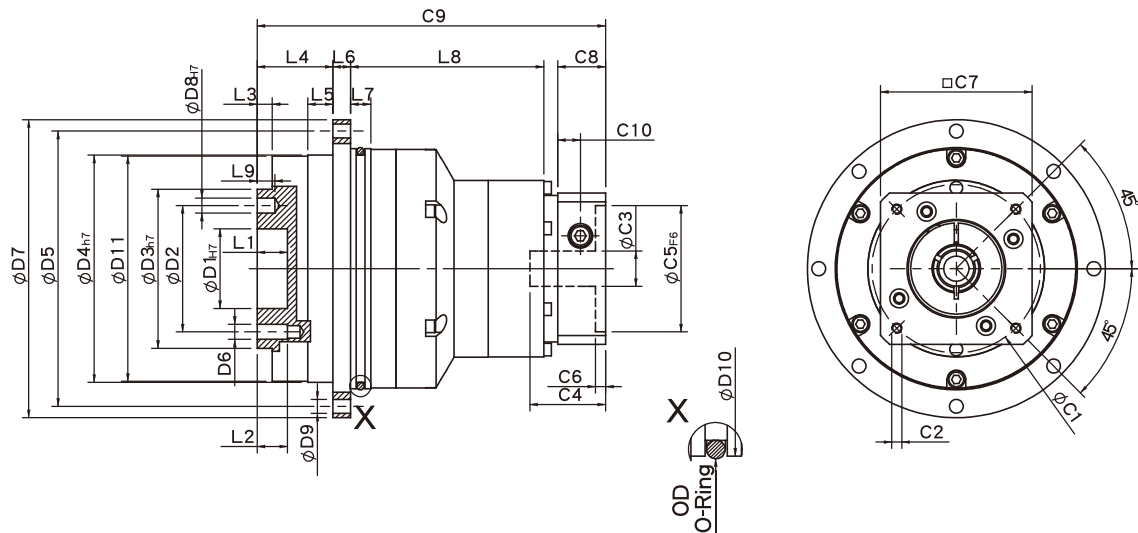

Specifications

Unit:mm

Dimensions	PHF60T	PHF90T	PHF115T	PHF142T	PHF200T	PHF255T
D1 _{H7}	20	31.5	40	50	80	100
D2	31.5	50	63	80	125	140
D3 _{h7}	40	63	80	100	160	180
D4 _{h7}	64	90	110	140	200	255
D5	79	109	135	168	233	280
D6	M5x0.8P	M6x1.0P	M6x1.0P	M8x1.25P	M10x1.5P	M16x2.0P
D7	86	118	145	179	247	300
D8 _{H7}	5	6	6	8	10	12
D9	4.5	5.5	5.5	6.6	9	13.5
D10	70	95	120	152	212	255
D11	63.2	89.2	109.2	139.2	199.2	254.2
L1	8	12	12	12	12	20
L2	7.2	12	13.5	16	22.5	30.5
L3	3	6	6	6	8	12
L4	19.5	30	29	38	50	66
L5	7	10	10	14.6	15	20
L6	4	7	8	10	12	18
L7	7.7	8	10	12	17	39.5
L8	65.2	69.5	93.5	110	161.7	192
L9	6	7	7	7	10	10
C1 ²	46	70	90	115	145	200
C2 ²	M4x0.7P	M5x0.8P	M6x1.0P	M8x1.25P	M8x1.25P	M12x1.75P
C3 ²	≤8/≤11	≤14/≤19	≤19/≤24	≤24/≤32/≤38	≤35/≤38	≤50
C4 ²	28.1	36.5	41.2	51.1	69.7	81
C5 ² _{F6}	30	50	70	95	110	114.3
C6 ²	4	4	6.7	6	8.5	6
C7 ²	42	60	90	115	140	180
C8 ²	16.5	19	25.5	30	38	40
C9 ²	113.2	138	163.1	198	281	335
C10 ²	7.4	9	11.3	13.9	17.8	21
OD	66x2	90x3	110x3	145x3	200x5	238x5

★ C1~C9 are motor specific dimensions(metric std shown), Size may vary according to motor flange.

★ Specification subject to change without notice.

PHF Flange Dimensions

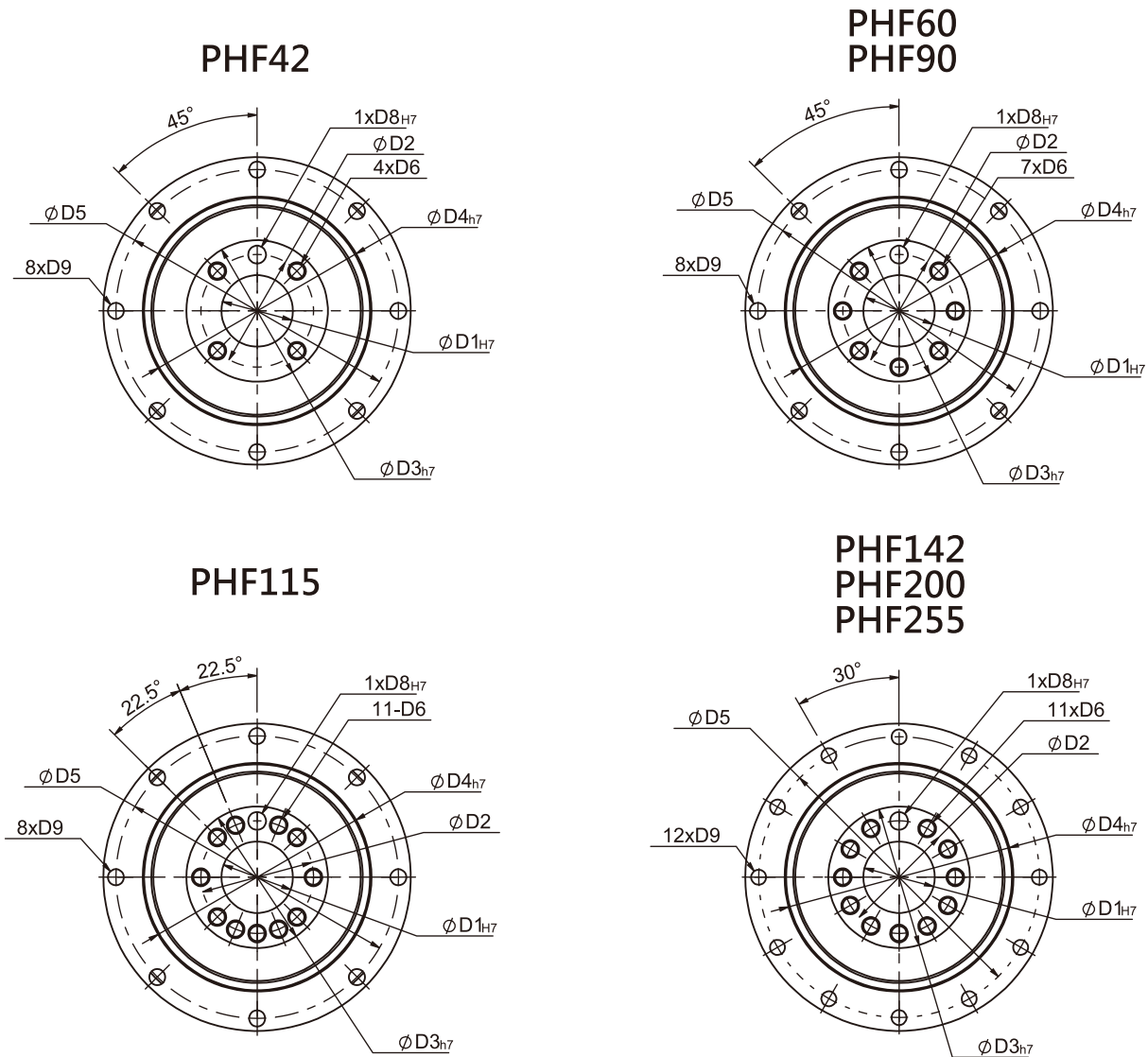

Specifications

Unit:mm

Dimensions	PHF42	PHF60	PHF90	PHF115	PHF142	PHF200	PHF255
D1 H7	12	20	31.5	40	50	80	100
D2	20	31.5	50	63	80	125	140
D3 h7	28	40	63	80	100	160	180
D4 h7	47	64	90	110	140	200	255
D5	67	79	109	135	168	233	280
D6	M3x0.5P	M5x0.8P	M6x1.0P	M6x1.0P	M8x1.25P	M10x1.5P	M16x2.0P
D8 H7	3	5	6	6	8	10	12
D9	3.4	4.5	5.5	5.5	6.6	9	13.5

★ Specification subject to change without notice.

PHF Specifications Table

Specifications		Stage	Ratio	PHF-42	PHF-60	PHF-90	PHF-115	PHF-142	PHF-200	PHF-255
Nominal Output Torque T_{2N}	N • m	1	3	-	40	105	180	340	580	1100
			4	16	43	110	240	500	1100	1700
			5	17	50	130	290	600	1200	2000
			7	14	44	125	270	530	1100	1750
			10	11	37	95	220	430	900	1450
		Stage	Ratio	PHF-42	PHF-60 (T)	PHF-90(T)	PHF-115T	PHF-142T	PHF-200T	PHF-255T
		2	15	-	40	105	180	600	1200	2000
			20	16	43	110	240	600	1200	2000
			25	17	50	130	290	600	1200	2000
			30	17	50	130	290	600	1200	2000
			35	17	50	130	290	600	1200	2000
			40	17	50	130	290	600	1200	2000
			50	17	50	130	290	600	1200	2000
			70	14	44	125	270	530	1100	1750
100	11	37	95	220	430	900	1450			
Emergency Stop Torque T_{2NOT}	N • m		3.0 times of Nominal Output Torque (* Max. Output Torque T_{2B} = 60% of Emergency Stop Torque)							
Nominal Input Speed n_{1N}	rpm	1,2	3-100	5000	5000	4000	4000	3000	3000	2000
Max. Input Speed n_{1max}	rpm	1,2	3-100	10000	10000	8000	8000	6000	5000	4000
Micro Backlash P0	arcmin	1	3-10	≤ 2	≤ 2	≤ 2	≤ 1	≤ 1	≤ 1	≤ 1
		2	12-100	≤ 4	≤ 4	≤ 4	≤ 3	≤ 3	≤ 3	≤ 3
Precision Backlash P1	arcmin	1	3-10	≤ 4	≤ 4	≤ 4	≤ 3	≤ 3	≤ 3	≤ 3
		2	12-100	≤ 6	≤ 6	≤ 6	≤ 5	≤ 5	≤ 5	≤ 5
Standard Backlash P2	arcmin	1	3-10	≤ 6	≤ 6	≤ 6	≤ 5	≤ 5	≤ 5	≤ 5
		2	12-100	≤ 8	≤ 8	≤ 8	≤ 7	≤ 7	≤ 7	≤ 7
Torsional Rigidity	N • m / arcmin	1,2	3-100	6	12	30	80	150	450	1000
Max. Bending Moment M_{2kB}^1	N • m	1,2	3-100	43	125	288	503	1470	2950	6080
Max. Axial Load F_{2aB}^1	N	1,2	3-100	1015	1340	2868	3890	9850	12560	21850
Operating Temp.	°C		3-100	-10 °C ~ +90 °C						
Service Life	hr		3-100	30,000 (15,000/ Continuous operation)						
Efficiency	%	1	3-10	≥ 97%						
		2	12-100	≥ 94%						
Weight	kg	1	3-10	0.7	1.5	3.3	6.2	13.6	32.1	63.3
		2	12-100	1.1	2.3/1.8	6.0/4.1	8.1	17.9	38.6	79.5
Mounting Position	-	1,2	3-100	Any direction						
Noise Level ²	dBA/1m	1,2	3-100	56	58	60	63	65	67	70
Protection Class	-	1,2	3-100	IP65						
Lubrication	-	1,2	3-100	Synthetic Lubricant						
Inertia(J1)										
Stage	Ratio	unit	PHF-42	PHF-60	PHF-90	PHF-115	PHF-142	PHF-200	PHF-255	
1	3	Kg • cm ²	-	0.19	0.72	2.35	9.05	29.80	72.50	
	4		0.02	0.18	0.67	1.66	7.17	25.86	58.21	
	5		0.02	0.17	0.65	1.50	6.52	23.63	54.36	
	7		0.02	0.14	0.60	1.45	6.17	22.92	54.12	
	10		0.02	0.14	0.58	1.41	6.10	22.73	53.98	
Stage	Ratio	PHF-42	PHF-60(T)	PHF-90(T)	PHF-115T	PHF-142T	PHF-200T	PHF-255T		
2	15/20/25	0.02	0.17(0.02)	0.65(0.17)	0.65	1.50	6.52	23.63		
	30/35/40	0.02	0.14(0.02)	0.60(0.14)	0.60	1.45	6.17	22.92		
	50/70/100	0.02	0.14(0.02)	0.58(0.14)	0.58	1.41	6.10	22.73		

* 1. Applied to the output shaft center @100rpm.

* 2. Measured at 3000 rpm with no load. These values are measured by gearbox with ratio = 10 (1-stage) or ratio = 100 (2-stage) at nominal input speed or 3000 rpm (if nominal input speed is higher than 3000 rpm) with no load.

※ The above figures/specifications are subject to change without prior notice.

Products due to human error, natural disasters or other factors lead to poor or damaged, will not be covered under warranty.

PGFR SERIES



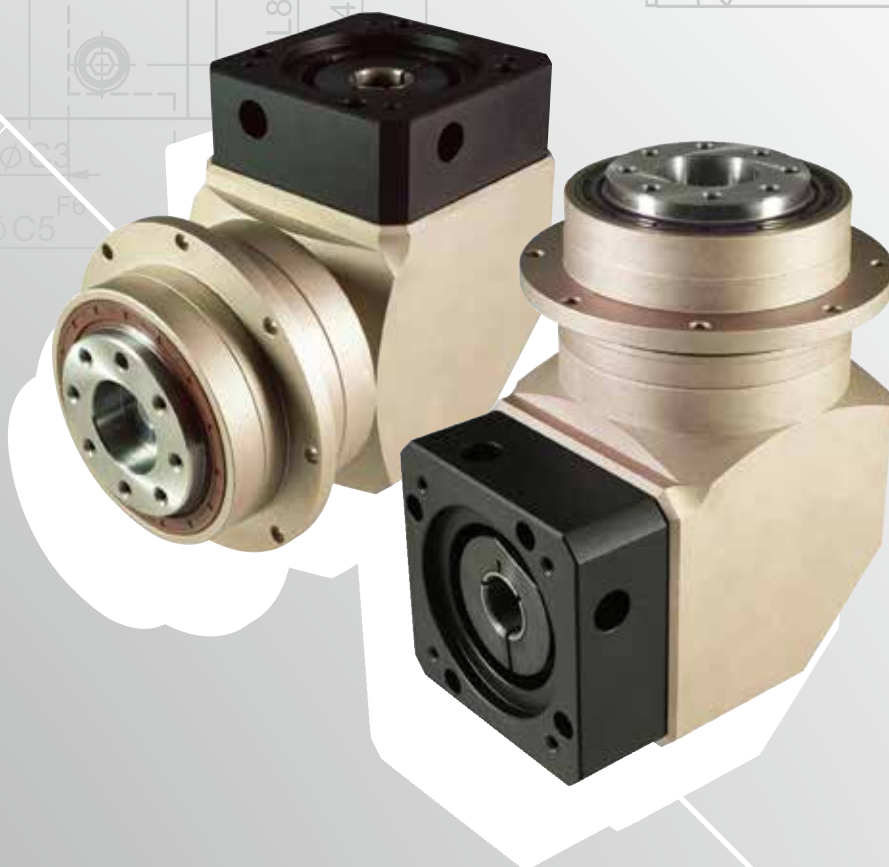
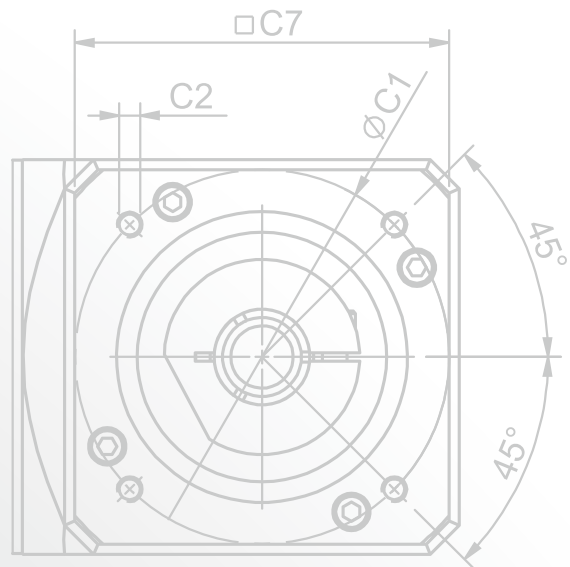
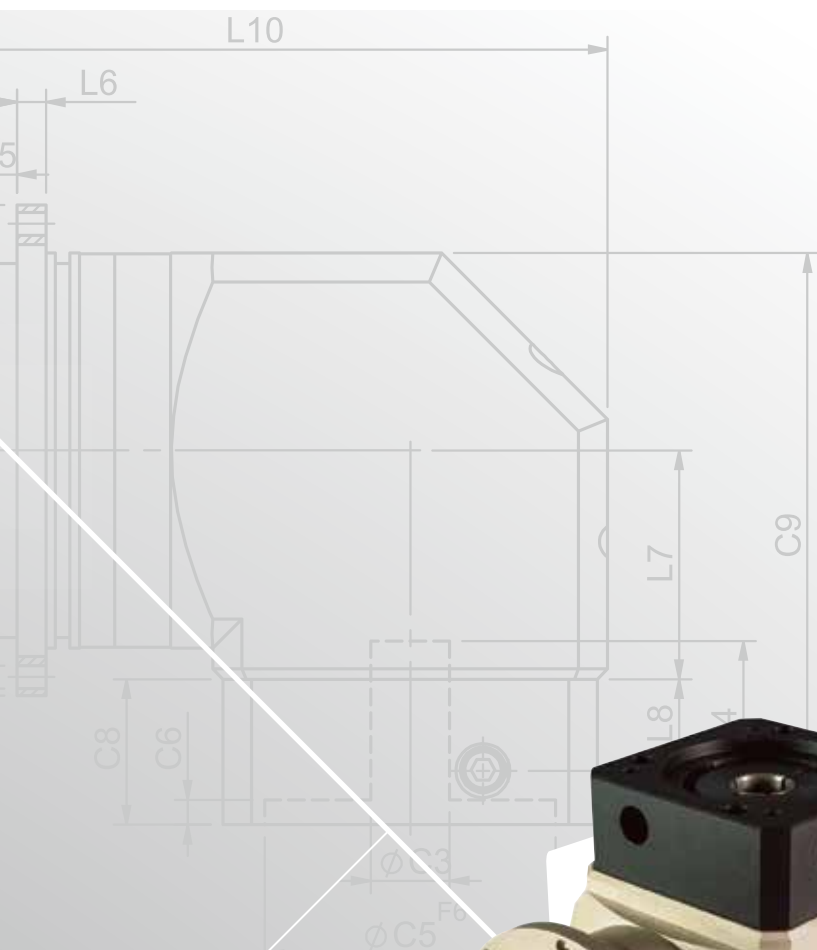

PGFR Single Stage Dimensions

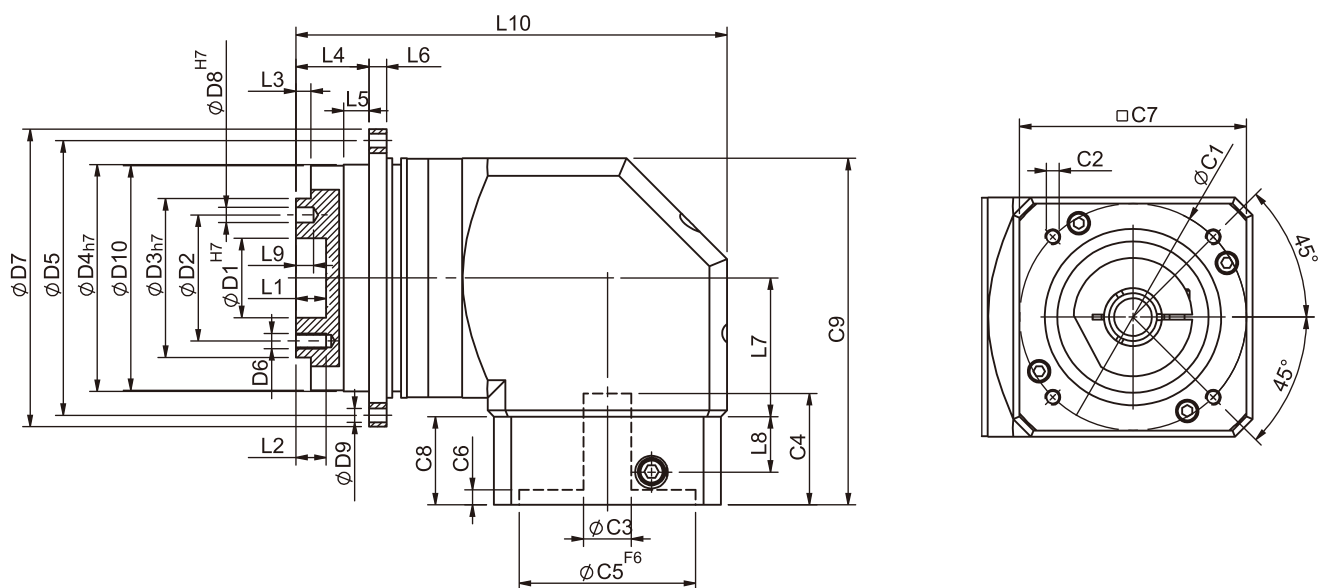

Specifications

Unit:mm

Dimensions	PGFR42	PGFR60	PGFR90	PGFR115
D1 _{H7}	12	20	31.5	40
D2	20	31.5	50	63
D3 _{h7}	28	40	63	80
D4 _{h7}	47	64	90	110
D5	67	79	109	135
D6	M3x0.5P	M5x0.8P	M6x1.0P	M6x1.0P
D7	72	86	118	145
D8 _{H7}	3	5	6	6
D9	3.4	4.5	5.5	5.5
D10	46.2	63.2	89.2	109.2
L1	4	8	12	12
L2	6	7.2	12	13.5
L3	3	3	6	6
L4	19.5	19.5	29	29
L5	7	7	10	10
L6	4	4	7	8
L7	32.2	44.8	55	69
L8	13.5	21.5	22	32
L9	4	6	7	7
L10	92.2	123.9	171.1	200.2
C1 ²	46	70	90	90
C2 ²	M4x0.7P	M5x0.8P	M6x1.0P	M6x1.0P
C3 ²	≤ 8	≤ 14	≤ 19/≤ 24	≤ 24/≤ 32
C4 ²	29	34	44	53.5
C5 ² _{F6}	30	50	70	70
C6 ²	6	5	5	5.5
C7 ²	42.6	60	90	115
C8 ²	25	33	35	48
C9 ²	78.5	112.8	137.5	176.5

★ C1~C9 are motor specific dimensions(metric std shown), Size may vary according to motor flange.

★ Specification subject to change without notice.

PGFR Double Stage Dimensions-1

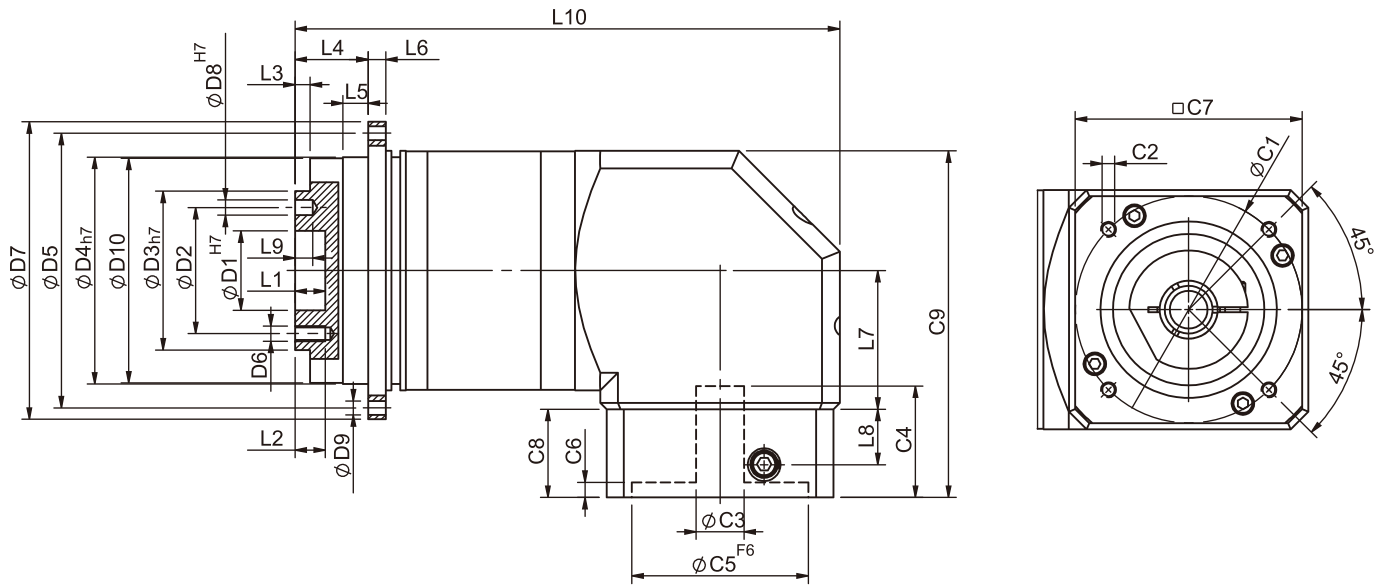

Specifications

Unit:mm

Dimensions	PGFR42	PGFR60	PGFR90
D1 _{H7}	12	20	31.5
D2	20	31.5	50
D3 _{h7}	28	40	63
D4 _{h7}	47	64	90
D5	67	79	109
D6	M3x0.5P	M5x0.8P	M6x1.0P
D7	72	86	118
D8 _{H7}	3	5	6
D9	3.4	4.5	5.5
D10	46.2	63.2	89.2
L1	4	8	12
L2	6	7.2	12
L3	3	3	6
L4	19.5	19.5	29
L5	7	7	10
L6	4	4	7
L7	32.2	44.8	55
L8	13.5	21.5	22
L9	4	6	7
L10	119.9	159.3	216.1
C1 ²	46	70	90
C2 ²	M4x0.7P	M5x0.8P	M6x1.0P
C3 ²	≤ 8	≤ 14	≤ 19/≤ 24
C4 ²	29	34	44
C5 ² _{F6}	30	50	70
C6 ²	6	5	5
C7 ²	42.6	60	90
C8 ²	25	33	35
C9 ²	78.5	112.8	137.5

* C1~C9 are motor specific dimensions(metric std shown), Size may vary according to motor flange.

* Specification subject to change without notice.

PGFR Double Stage Dimensions-2

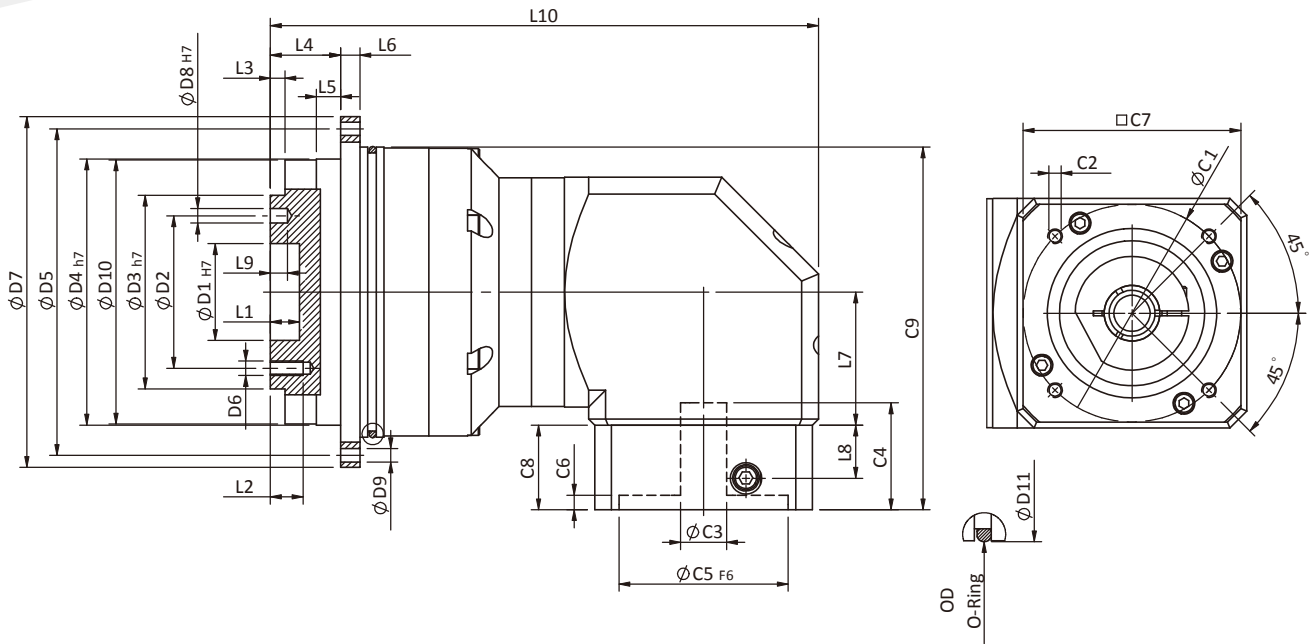

Specifications

Unit:mm

Dimensions	PGFR60T	PGFR90T	PGFR115T	PGFR142T
D1 _{H7}	20	31.5	40	50
D2	31.5	50	63	80
D3 _{h7}	40	63	80	100
D4 _{h7}	64	90	110	140
D5	79	109	135	168
D6	M5x0.8P	M6x1.0P	M6x1.0P	M8x1.25P
D7	86	118	145	179
D8 _{H7}	5	6	6	8
D9	4.5	5.5	5.5	6.6
D10	63.2	89.2	109.2	139.2
D11	70	95	120	152
L1	8	12	12	12
L2	7.2	12	13.5	16
L3	3	6	6	6
L4	19.5	29	29	38
L5	7	10	10	14.6
L6	4	7	8	10
L7	32.2	44.8	55	69
L8	13.5	21.5	22	32
L9	6	7	7	7
L10	126.6	171.3	226.6	270.7
C1 ²	46	70	90	90
C2 ²	M4x0.7P	M5x0.8P	M6x1.0P	M6x1.0P
C3 ²	≤ 8/≤ 11	≤ 14/≤ 19	≤ 19/≤ 24	≤ 24/≤ 32
C4 ²	29	34	44	53.5
C5 ² _{F6}	30	50	70	70
C6 ²	6	5	5	5.5
C7 ²	42.6	60	90	115
C8 ²	25	33	35	48
C9 ²	84.4	125.3	150	176.5
OD	66x2	90x3	110x3	145x3

* C1~C9 are motor specific dimensions(metric std shown), Size may vary according to motor flange.

* Specification subject to change without notice.

PGFR Flange Dimensions

PGFR42

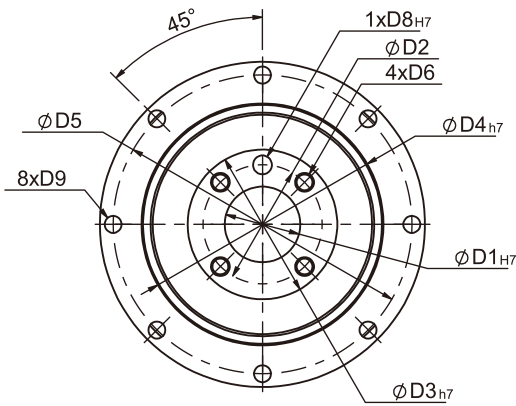

PGFR60 PGFR90

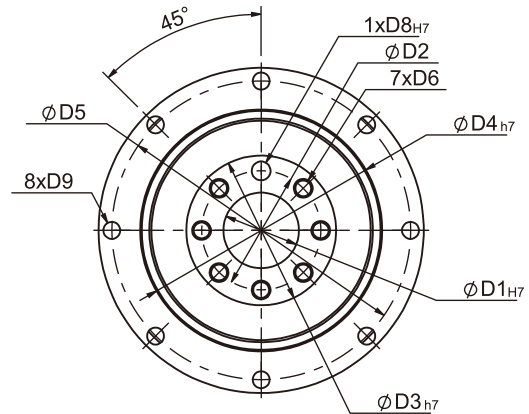

PGFR115

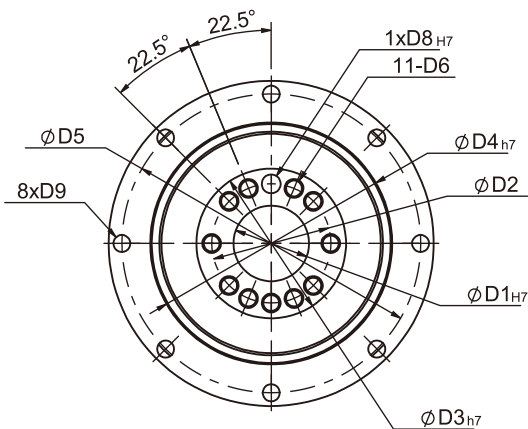

PGFR142

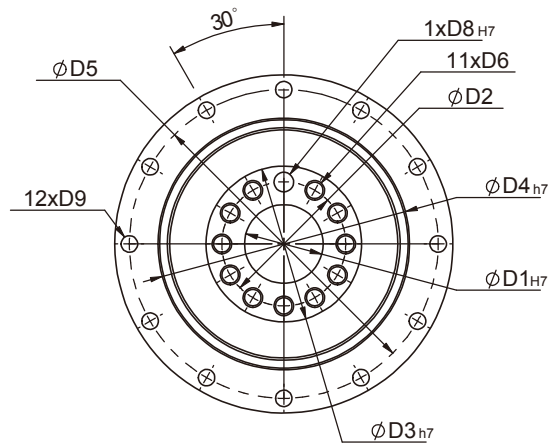

Specifications

Unit:mm

Dimensions	PGFR42	PGFR60	PGFR90	PGFR115	PGFR142
D1 _{H7}	12	20	31.5	40	50
D2	20	31.5	50	63	80
D3 _{h7}	28	40	63	80	100
D4 _{h7}	47	64	90	110	140
D5	67	79	109	135	168
D6	M3x0.5P	M5x0.8P	M6x1.0P	M6x1.0P	M8x1.25P
D8 _{H7}	3	5	6	6	8
D9	3.4	4.5	5.5	5.5	6.6

★ Specification subject to change without notice.

PGFR Specifications Table

Specifications		Stage	Ratio	PGFR-42	PGFR-60	PGFR-90	PGFR-115	PGFR-142
Nominal Output Torque T_{2N}	N • m	1	3	-	40	105	180	340
			4	16	43	110	240	500
			5	17	50	130	290	600
			7	14	44	125	270	530
			10	17	50	130	260	540
			14	14	44	125	270	530
		20	11	37	95	220	430	
		Stage	Ratio	PGFR-42	PGFR-60 PGFR-60T	PGFR-90 PGFR-90T	PGFR-115T	PGFR-142T
		2	15	-	40	105	180	600
			20	16	43	110	240	600
			25	17	50	130	290	600
			30	17	40	105	180	600
			35	17	50	130	290	600
			40	16	43	110	240	600
			50	17	50	130	290	600
			70	14	44	125	270	530
			100	11	37	95	220	430
			140	14	44	125	270	530
		200	11	37	95	220	430	
Emergency Stop Torque T_{2NOT}	N • m	3.0 times of Nominal Output Torque (*Max. Output Torque T_{2B} = 60% of Emergency Stop Torque)						
Nominal Input Speed n_{1N}	rpm	1,2	3-200	5000	5000	4000	4000	3000
Max. Input Speed n_{1max}	rpm	1,2	3-200	10000	10000	8000	8000	5000
Micro Backlash P0	arcmin	1	3-20	-	-	≤ 4	≤ 2	≤ 2
		2	15-200	-	-	≤ 6	≤ 4	≤ 4
Precision Backlash P1	arcmin	1	3-20	≤ 6	≤ 6	≤ 6	≤ 4	≤ 4
		2	15-200	≤ 8	≤ 8	≤ 8	≤ 7	≤ 7
Standard Backlash P2	arcmin	1	3-20	≤ 8	≤ 8	≤ 8	≤ 6	≤ 6
		2	15-200	≤ 10	≤ 10	≤ 10	≤ 9	≤ 9
Torsional Rigidity	N • m / arcmin	1,2	3-200	6	12	28	75	145
Max. Bending Moment M_{2kB}^1	N • m	1,2	3-200	22.5	36	76	140	950
Max. Axial Load F_{2aB}^1	N	1,2	3-200	465	635	1060	1580	6400
Operating Temp.	°C	-10 °C ~ +90 °C						
Service Life	hr	20,000 (10,000/Continuous operation)						
Efficiency	%	1	3-20	≥ 95%				
		2	15-200	≥ 92%				
Weight	kg	1	3-20	1.1	2.2	6.3	13.5	25.1
		2	15-200	1.6	2.9/2.1	8.3/5.0	14.8	26.7
Mounting Position	-	1,2	3-200	Any direction				
Noise Level ²	dBA/1m	1,2	3-200	62	64	66	68	70
Protection Class	-	1,2	3-200	IP65				
Lubrication	-	1,2	3-200	Synthetic Lubricant				
Inertia(J1)								
Stage	Ratio	unit		PGFR-42	PGFR-60	PGFR-90	PGFR-115	PGFR-142
1	3/4/5/7/9	Kg • cm ²		0.06	0.40	2.28	6.87	24.2
	10/14/20			0.05	0.30	1.45	4.76	14.5
2	15/20/25/35			PGFR-42	PGFR-60(T)	PGFR-90(T)	PGFR-115T	PGFR-142T
	others			0.06	0.40(0.08)	2.28(0.72)	3.02	7.83
				0.05	0.30(0.06)	1.45(0.38)	1.64	5.00

* 1. Applied to the output shaft center @100rpm.
* 2. Measured at 3000 rpm with no load. These values are measured by gearbox with ratio = 10 (1-stage) or ratio = 100 (2-stage) at nominal input speed or 3000 rpm (if nominal input speed is higher than 3000 rpm) with no load.
※ The above figures/specifications are subject to change without prior notice.

Products due to human error, natural disasters or other factors lead to poor or damaged, will not be covered under warranty.

PGF SERIES

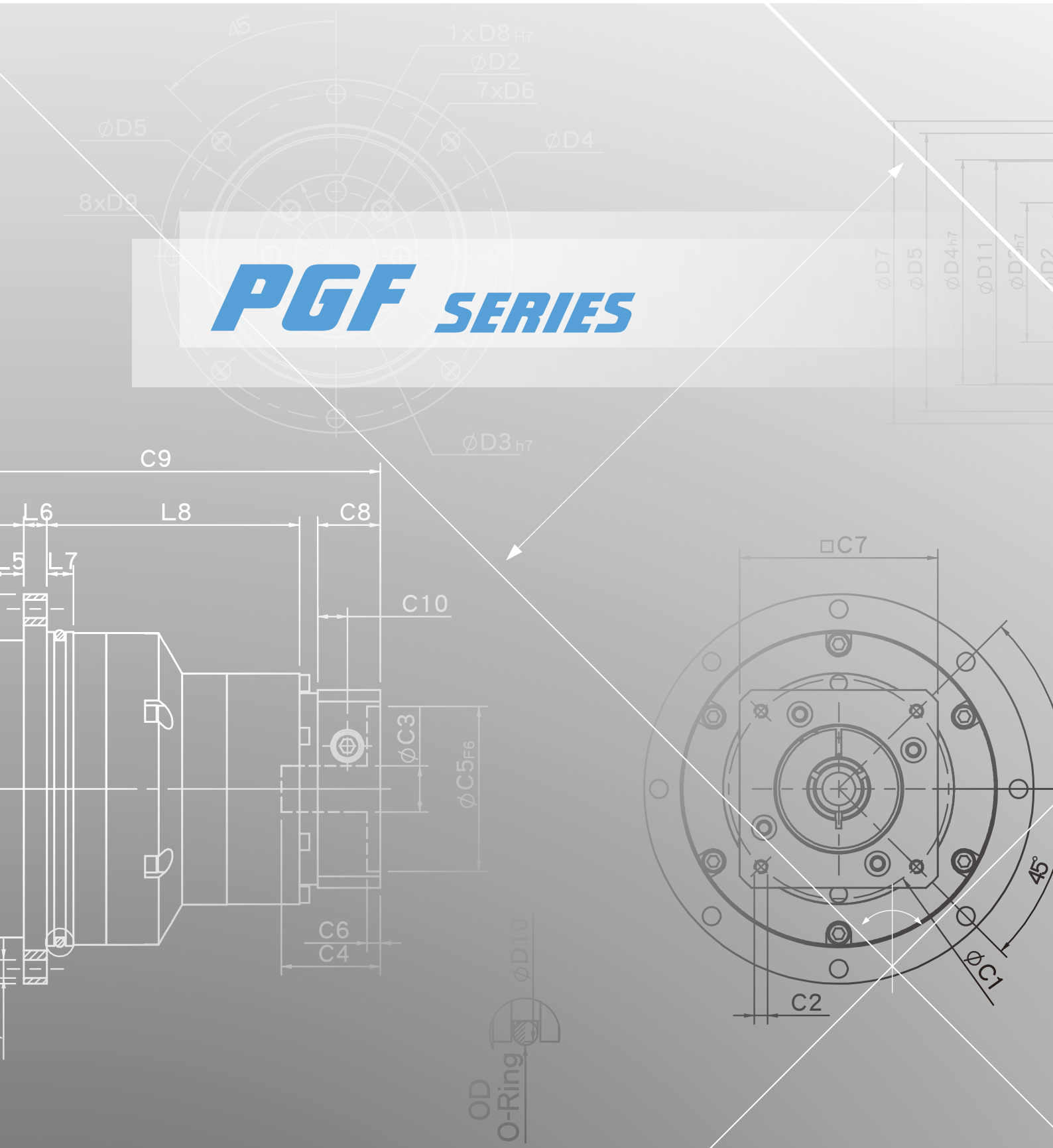

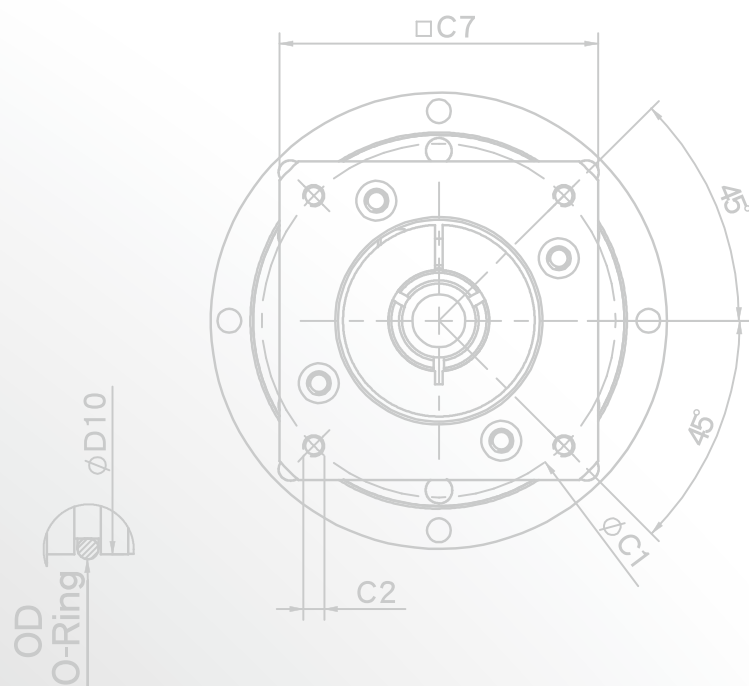
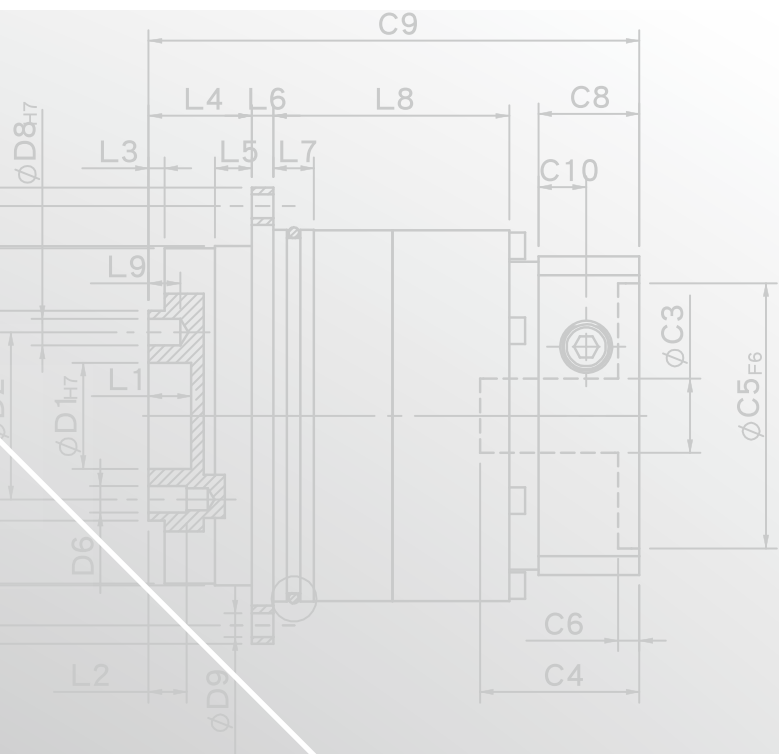

PGF SERIES FEATURES

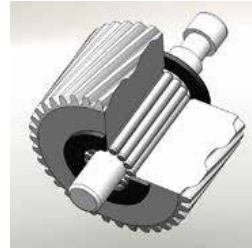

Planet gear transmission interface equipped with needle bearings, full needle roller bearings aligned without retainer achieve maximum exposure but smallest gap tolerances. Enhance over-all gear structure rigid and output torque.

Alloy steel gear with unique heat treatment. Additionally, with gear grinding processing to get the best accuracy, high wear resistance and high impact toughness.

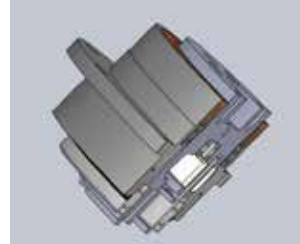
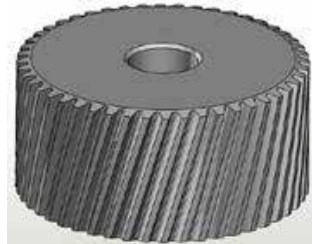

The sun gear bearing is placed directly into the planetary arm bracket, the overall mechanical structure designed to ensure concentricity of the transmission components.



Input-end and motor shaft are coupled through a dynamic balanced collar clamping mechanism to ensure connection interface concentricity and zero slip power transmission at high speed.

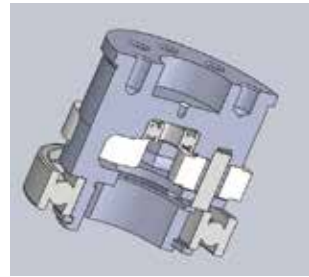

Planetary arm bracket and output shaft are one-piece constructed, setting bearing apart for larger span to reach the largest reverse rigid and contribute high axis radial load capacity.

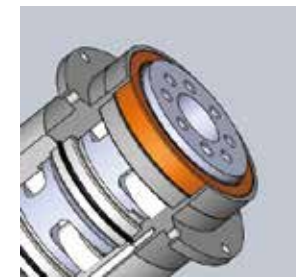
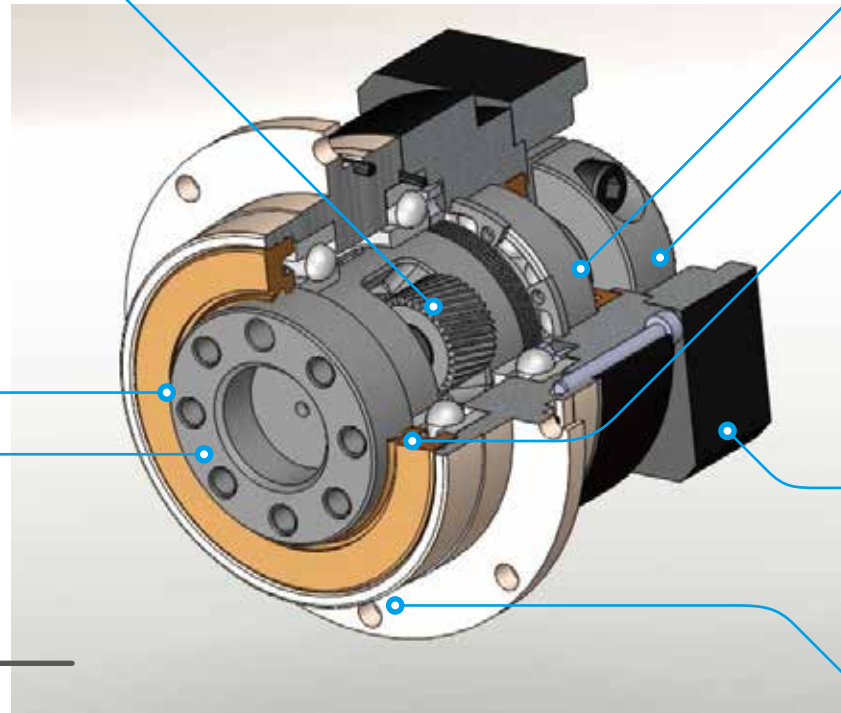

High-tech oil seal design on the upper lip guard against dust intruder, lower lip to guard against oil leak. Protection grade IP65 safeguards fully avoid leaking problem, and given it maintenance-free.

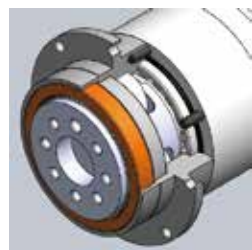

Grinding process to smooth surface of output shaft, and with oil-seal to minimum friction coefficient and reducing start up load; result in the best seal-ability and extended lifespan. Hollow out-put shaft connects perfectly with circular flange drastically reducing the installation space.

PGF Series overall design suitable for combination operation with servo motor high-speed input and achieves maximum torque output. Hollow out-put shaft connects perfectly with circular flange drastically reducing the installation space. Precision gear design and gear processing create a planetary gearhead with low backlash operation, high efficiency, low noise and long lifespan.

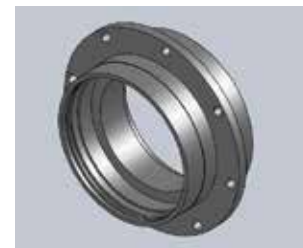

Advanced electroless nickel plating surface treatment resists scratch and corrosion. Suitable for stringent require of high-tech equipment. The gear box and internal gear ring are one-piece constructed, and then processed with advanced Germany gear shaper machinery for high-precision, high torque and abrade consumption.

Products due to human error, natural disasters or other factors lead to poor or damaged, will not be covered under warranty.

PHL
PHR
PHL
PGH
PUR
PUL
PGLH
PCL
PGC
PGE
PGRH
PGR
PGFR
PGF
PBC
PBE
PAE
PAC
PAN
PGS
PNS

PGF Single Stage Dimensions

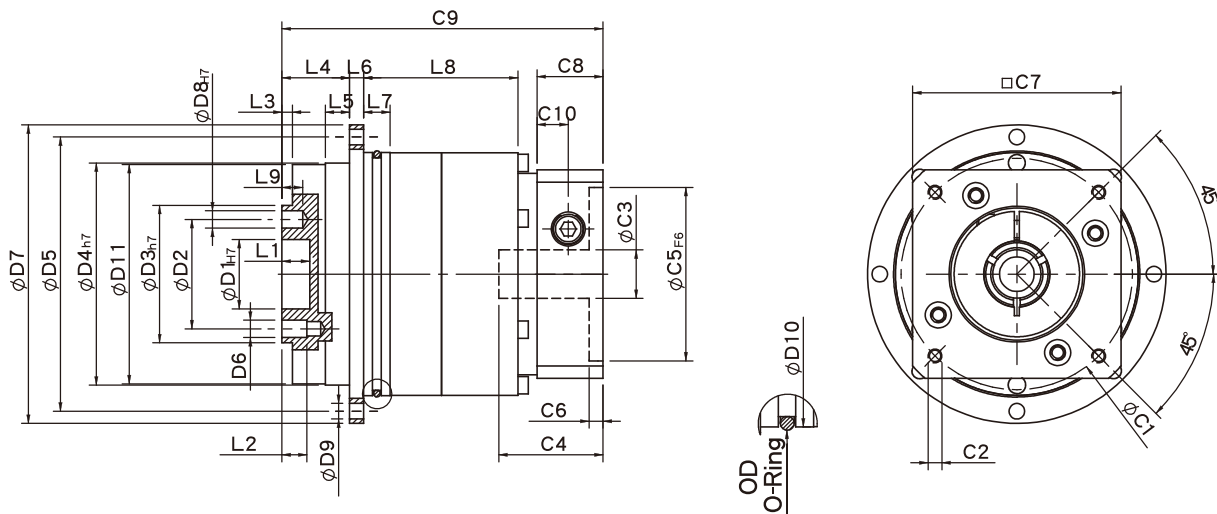

Specifications

Unit:mm

Dimensions	PGF42	PGF60	PGF90	PGF115	PGF142
D1 _{H7}	12	20	31.5	40	50
D2	20	31.5	50	63	80
D3 _{h7}	28	40	63	80	100
D4 _{h7}	47	64	90	110	140
D5	67	79	109	135	168
D6	M3x0.5P	M5x0.8P	M6x1.0P	M6x1.0P	M8x1.25P
D7	72	86	118	145	179
D8 _{H7}	3	5	6	6	8
D9	3.4	4.5	5.5	5.5	6.6
D10	60	70	95	120	152
D11	46.2	63.2	89.2	109.2	139.2
L1	4	8	12	12	12
L2	6	7.2	12	13.5	16
L3	3	3	6	6	6
L4	19.5	19.5	29	29	38
L5	7	7	10	10	14.6
L6	4	4	7	8	10
L7	5	7.7	8	10	12
L8	25	29.5	35	50.5	65
L9	4	6	7	7	7
C1 ²	46	70	90	115	145
C2 ²	M4x0.7P	M5x0.8P	M6x1.0P	M8x1.25P	M8x1.25P
C3 ²	≤8/≤11	≤14/≤19	≤19/≤24	≤24/≤32/≤38	≤35/≤38
C4 ²	28.6	37.5	41.7	51.1	66.7
C5 ² _{F6}	30	50	70	95	110
C6 ²	4	4	6.7	6	5.5
C7 ²	42	60	90	115	140
C8 ²	16.5	19	25.5	30	35
C9 ²	74.8	84.5	104.5	127.5	168.5
C10 ²	7.4	9	11.3	13.9	17.8
OD	56x2	66x2	90x3	110x3	145x3

★ C1~C9 are motor specific dimensions(metric std shown), Size may vary according to the motor flange chosen.

★ Specification subject to change without notice.

PGF Double Stage Dimensions-1

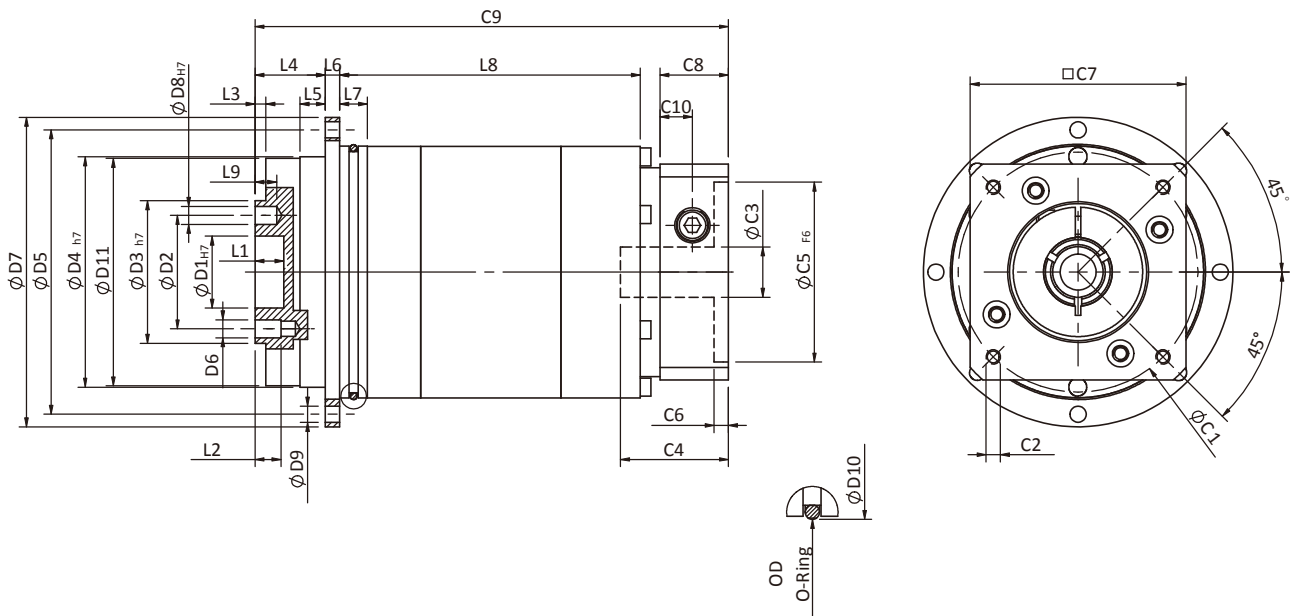

Specifications

Unit:mm

Dimensions	PGF42	PGF60	PGF90
D1 H7	12	20	31.5
D2	20	31.5	50
D3 h7	28	40	63
D4 h7	47	64	90
D5	67	79	109
D6	M3x0.5P	M5x0.8P	M6x1.0P
D7	72	86	118
D8 H7	3	5	6
D9	3.4	4.5	5.5
D10	60	70	95
D11	46.2	63.2	89.2
L1	4	8	12
L2	6	7.2	12
L3	3	3	6
L4	19.5	19.5	29
L5	7	7	10
L6	4	4	7
L7	5	7.7	8
L8	54.5	68.5	80
L9	4	6	7
C1 ²	46	70	90
C2 ²	M4x0.7P	M5x0.8P	M6x1.0P
C3 ²	≤8/≤11	≤14/≤19	≤19/≤24
C4 ²	28.6	37.5	41.7
C5 ² F6	30	50	70
C6 ²	4.1	4.5	6
C7 ²	42	60	90
C8 ²	17	20	26
C9 ²	103	124.5	149.1
C10 ²	7.4	9	11.3
OD	56x2	66x2	90x3

* C1~C9 are motor specific dimensions(metric std shown), Size may vary according to the motor flange chosen.

* Specification subject to change without notice.

PGF Double Stage Dimensions-2

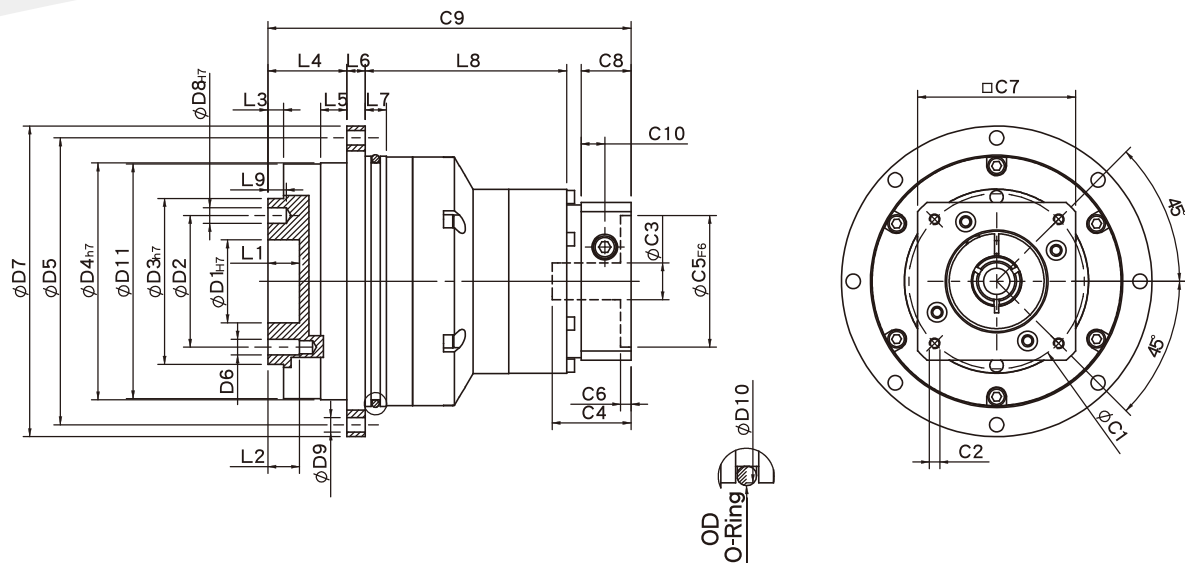

Specifications

Unit:mm

Dimensions	PGF60T	PGF90T	PGF115T	PGF142T
D1 _{H7}	20	31.5	40	50
D2	31.5	50	63	80
D3 _{h7}	40	63	80	100
D4 _{h7}	64	90	110	140
D5	79	109	135	168
D6	M5x0.8P	M6x1.0P	M6x1.0P	M8x1.25P
D7	86	118	145	179
D8 _{H7}	5	6	6	8
D9	4.5	5.5	5.5	6.6
D10	70	95	120	152
D11	63.2	89.2	109.2	139.2
L1	8	12	12	12
L2	7.2	12	13.5	16
L3	3	6	6	6
L4	19.5	29	29	38
L5	7	10	10	14.6
L6	4	7	8	10
L7	7.7	8	10	12
L8	61.2	68	89.5	110
L9	6	7	7	7
C1 ²	46	70	90	115
C2 ²	M4x0.7P	M5x0.8P	M6x1.0P	M8x1.25P
C3 ²	≤8/≤11	≤14/≤19	≤19/≤24	≤24/≤32/≤38
C4 ²	28.6	37.5	41.7	51.1
C5 ² _{F6}	30	50	70	95
C6 ²	4.1	4.5	6	6
C7 ²	42	60	90	115
C8 ²	17	20	26	30
C9 ²	109.7	136.5	159.6	198
C10 ²	7.4	9	11.3	13.9
OD	66x2	90x3	110x3	145x3

★ C1~C9 are motor specific dimensions(metric std shown), Size may vary according to the motor flange chosen.

★ Specification subject to change without notice.

PGF Flange Dimensions

PGF42

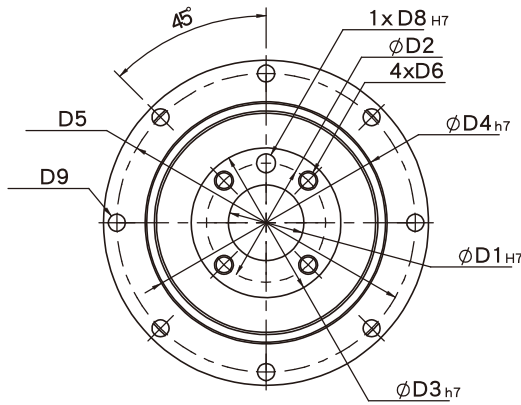

PGF60 PGF90

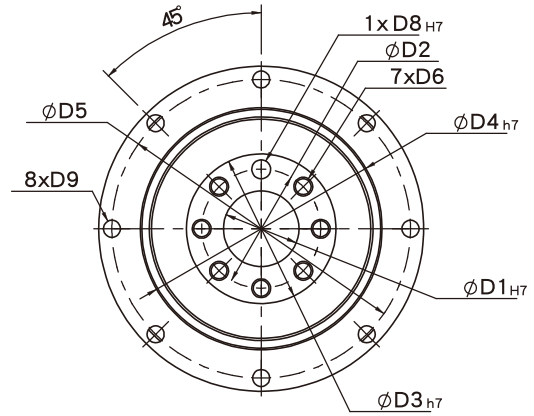

PGF115

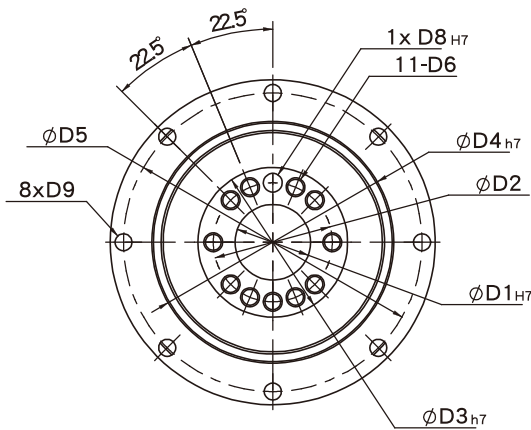

PGF142

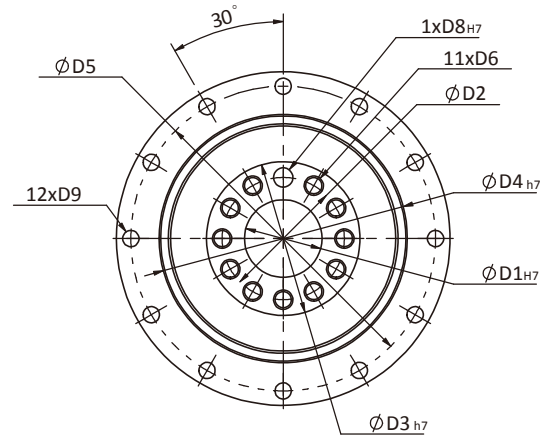

Specifications

Unit:mm

Dimensions	PGF42	PGF60	PGF90	PGF115	PGF142
D1 H7	12	20	31.5	40	50
D2	20	31.5	50	63	80
D3 h7	28	40	63	80	100
D4 h7	47	64	90	110	140
D5	67	79	109	135	168
D6	M3x0.5P	M5x0.8P	M6x1.0P	M6x1.0P	M8x1.25P
D8 H7	3	5	6	6	8
D9	3.4	4.5	5.5	5.5	6.6

★ Specification subject to change without notice.

PGF Specifications Table

Specifications		Stage	Ratio	PGF-42	PGF-60	PGF-90	PGF-115	PGF-142
Nominal Output Torque T_{2N}	N • m	1	3	-	40	105	180	340
			4	16	43	110	240	500
			5	17	50	130	290	600
			7	14	44	125	270	530
			10	11	37	95	220	430
		Stage	Ratio	PGF-42	PGF-60(T)	PGF-90(T)	PGF-115T	PGF-142T
		2	15	-	40	105	180	600
			20	16	43	110	240	600
			25	17	50	130	290	600
			30	17	50	130	290	600
			35	17	50	130	290	600
			40	17	50	130	290	600
			50	17	50	130	290	600
			70	14	44	125	270	530
100	11	37	95	220	430			
Emergency Stop Torque T_{2NOT}	N • m	3.0 times of Nominal Output Torque (*Max. Output Torque T_{2B} = 60% of Emergency Stop Torque)						
Nominal Input Speed n_{1N}	rpm	1,2	3-100	5000	5000	4000	4000	3000
Max. Input Speed n_{1max}	rpm	1,2	3-100	10000	10000	8000	8000	5000
Micro Backlash P0	arcmin	1	3-10	≤ 3	≤ 3	≤ 3	≤ 1	≤ 1
		2	12-100	≤ 5	≤ 5	≤ 5	≤ 3	≤ 3
Precision Backlash P1	arcmin	1	3-10	≤ 5	≤ 5	≤ 5	≤ 3	≤ 3
		2	12-100	≤ 7	≤ 7	≤ 7	≤ 5	≤ 5
Standard Backlash P2	arcmin	1	3-10	≤ 7	≤ 7	≤ 7	≤ 5	≤ 5
		2	12-100	≤ 9	≤ 9	≤ 9	≤ 7	≤ 7
Torsional Rigidity	N • m /arcmin	1,2	3-100	6	12	28	75	145
Max. Bending Moment M_{2kB}^1	N • m	1,2	3-100	22.5	36	76	140	950
Max. Axial Load F_{2aB}^1	N	1,2	3-100	465	635	1060	1580	6400
Operating Temp.	°C	-10 °C ~ +90 °C						
Service Life	hr	20,000 (10,000/ Continuous operation)						
Efficiency	%	1	3-10	≥ 97%				
		2	12-100	≥ 94%				
Weight	kg	1	3-10	0.7	1.4	3.2	6.0	13.6
		2	12-100	1.1	2.2/1.7	5.0/4.0	7.9	17.9
Mounting Position	-	1,2	3-100	Any direction				
Noise Level ²	dB(A)/1m	1,2	3-100	56	58	60	63	65
Protection Class	-	1,2	3-100	IP65				
Lubrication	-	1,2	3-100	Synthetic Lubricant				
Inertia(J1)								
Stage	Ratio	unit		PGF-42	PGF-60	PGF-90	PGF-115	PGF-142
1	3	Kg • cm ²		-	0.19	0.72	2.35	9.05
	4			0.02	0.18	0.67	1.66	7.17
	5			0.02	0.17	0.65	1.50	6.52
	7			0.02	0.14	0.60	1.45	6.17
	10			0.02	0.14	0.58	1.41	6.10
Stage	Ratio			PGF-42	PGF-60(T)	PGF-90(T)	PGF-115T	PGF-142T
2	15/20/25			0.02	0.17(0.02)	0.65(0.17)	0.65	2.35
	30/35/40			0.02	0.14(0.02)	0.60(0.14)	0.60	1.45
	50/70/100			0.02	0.14(0.02)	0.58(0.14)	0.58	1.41

* 1. Applied to the output shaft center @100rpm.
* 2. Measured at 3000 rpm with no load. These values are measured by gearbox with ratio = 10 (1-stage) or ratio = 100 (2-stage) at nominal input speed or 3000 rpm (if nominal input speed is higher than 3000 rpm) with no load.
※ The above figures/specifications are subject to change without prior notice.

Products due to human error, natural disasters or other factors lead to poor or damaged, will not be covered under warranty.